



UNIVERSITEIT•STELLENBOSCH•UNIVERSITY
jou kennisvenoot • your knowledge partner

UNAKEKELO LWABANTU ABANESIFO SOKUFA ICALA

EKHAYA



Iqulunqwe kwaye yahlelwa ngu-ES Scheffler no-SJ Visagie

Icandelo leziFundo zokuBuyisela kwimeko yesiqhelo, eYunivesithi yaseStellenbosch

Igama:

Umqeqeshi okanye/Ugqirha:

Inombolo yomnxeba:



Ilungelo lokukopa © 2011 Iyunivesithi yaseStellenbosch. Onke amalungelo agciniwe. Uhlelo oluphinde lwajongwa © 2015 Iyunivesithi yaseStellenbosch. Onke amalungelo agciniwe.

Ilungelo lokukopa ihlelo lesiXhosa @ 2015 Iyunivesithi yaseStellenbosch. Onke amalungelo agciniwe.

Imveliso yeNdawo yeziFundo zokuBuyiselwa kwimeko yesiqhelo, eYunivesithi yaseStellenbosch

Ishicilelwe kwaye yaveliswa eMzantsi Afrika.

Ushicilelo olukumatshini osebenza ngombane: Imimiselo yokuyisebenzisa

1. Olu shicilelo lukumatshini osebenza ngombane lungaphinda luphuhlise, lusasazwe, lugcinwe okanye ludluliselwe ngokupheleleyo, kungakhange kushiye maphepha.
2. Abasebenzisi bangaphinde baphuhlise okanye basasaze olu shicilelo lukumatshini osebenza ngombane ngendlela yokuprinta okanye yombane ngaphantsi kwale miqathango.
 - i Onke amaphepha encwadana, kuquka amaphepha angaphambili nangasemva, kufuneka aphinde aveliswe aze asasazwe ixesha ngalinye.
 - ii Iikopi zoshicilelo olukumatshini osebenza ngombane azinako ukuthengiselwa inzuzo.
 - iii Akukho nxalenye yolu shicilelo lukumatshini osebenza ngombane engalungiswa nangayiphi indlela okanye ngohlobo lonxibelelwano ngaphandle kwemvume ebhalwe kwangaphambili ngumnini onelungelo lekopi.

Yisa nayiphi imibuzo okanye uqhagamshelane nalowo unelungelo lobunini bekopi:

Head of Department
Centre for Rehabilitation Studies
Stellenbosch University
PO Box 241
Cape Town
8000

South Africa

Umnxeba: +27 21 938 9528

Ifeksi: +27 21 931 9835

i-lmeyile: CRS@sun.ac.za

Iziqulatho

1. Izinto ezibalulekile ekufuneka uzazi ngesifo sokufa icala	2
2. Iingxaki zonzibelelwano	4
3. Iingxaki zengqondo (ukucinga) nendlela yokuziphatha	7
4. Indlela yokubeka umntu okhe wanesifo sokufa icala	8
5. Ukutya, ukuginya kunye nonakekelo lwamazinyo/okanye unakekelo lomlomo	14
6. Ukhathalelo lwamagxa	20
7. Ukushukuma ebhedini	24
8. Ukugqithisela (ukusuka ebhedini ukuya esitulweni)	29
9. Ukuzikhathalela	35
10. Ukuncediswa xa uhamba	49
11. Iingxaki eziqhelekileyo emva kwesifo sokufa icala	50
Imibulelo	51
Kutheni sibhale le ncwadana?	52

1. Izinto ezibalulekileyo ekufuneka uzazi ngesifo sokufa icala

? Yintoni isifo sokufa icala?

Isifo sokufa icala senzeka xa kukhona iingxaki zokuhamba kwegazi ukuya kwindawo ethile yengqondo. Ezi ngxaki zingayenye yezi zilandelayo:

- Umonakalo okanye intsholongwane ingavala okanye icuthe imithambo yegazi. Oko kunqanda ukuhamba kwegazi, into ethetha ukuba umongo-moya okanye i-okhsijini (umoya) kunye nezakha-mzimba (ukutya) azinako ukufikelela kwiindawo ezithile zengqondo. Ezo ndawo zengqondo ziye zimoshakale kwaye zingayeka ukusebenza.
- Umthambo wegazi ungagqabhuka. Igazi liza kuzalisa ingqondo lize lenze umonakalo.

? Bayalulama abantu emva kwesifo sokufa icala?

Isifo sokufa icala ngasinye sahlukile. Kuxhomekeka kwindawo leyo yengqondo emoshakeleyo.

- Ngesiqhelo, abantu abasindileyo kwisifo sokufa icala baye babe ngcono emva kwexesha elide, kodwa baphantse bangaphili ncam.
- Abantu abaninzi bangaphinde bakwazi ukuhamba kwakhona, kodwa bahamba kancinane kwaye bangawa lula.
- Abantu abaninzi abayifumani kwakhona yonke intshukumo okanye ulawulo lwesandla sabo kunye nolwengalo yabo.
- Eminye imisipha ihlala ikhubazekile okanye ibuthathaka, kwaye eminye iye iqine. Oku kwenza kube nzima kubantu abasinde kwisifo sokufa icala ukuba bashukume okanye balawule imizimba yabo.
- Indlela yabanye abantu yokusebenza komzimba (iintshukumo zomzimba kunye nolawulo) iye iphinde ibe ngathi ibuyela esiqhelweni.
- Abanye baye baqhubeka nokuba neengxaki zendlela esebenza ngayo ingqondo (ezifana nokucinga, ukwenza izigqibo kunye nokwazi ukuba bahlalele kude nengozi).

? Amayeza angasenza sibe ngcono isifo sokufa icala?

Akukwazeki ukwenza ukuba kwenziwe iiseli zengqondo ezifileyo kwakhona. Kodwa ukuba unyanga iingxaki ezenza isifo sokufa icala, unganceda ekunqandeni ezinye izifo zokufa icala. Iingxaki eziqhelekileyo ezenza isifo sokufa icala sisifo seswekile (isifo seswekile enyukileyo), uxinzelelo oluphezulu lwegazi, ikholesteroli ephezulu (amafutha amaninzi kakhulu egazini) kunye neengxaki zentliziyo. Umntu owakhe waba nesifo sokufa icala kufuneka abonane nogqirha ukuze anyangelwe ezi zifo kunye nokuba kujongwe ukuba azikho na ezinye iingxaki.

? Zeziphi iingxaki abantu abadla ngokuziva emva kwesifo sokufa icala?

Abantu banganezi ngxaki zilandelayo emva kwesifo sokufa icala:

- Ubuthathaka okanye ukukhubazeka kwecala lomzimba.
- Ukuqina kwengalo, isandla okanye unyawo
- Bayanzinyelwa kukuzinza, bawa lula xa behleli naxa bemile
- Bayanzinyelwa kukuthetha okanye ukuqonda ulwimi
- Bayanzinyelwa kukulawula isinyi sabo nomchamo (iimfuno zendlu yangasese) (kodwa oku kudla ngokuba ngcono ngokuhamba kwexesha)
- Ukulahlekelwa yimvakalelo yeli cala libuthathaka lemizimba yabo.
- Ingathi bayalilibala/abalihoyi icala elibuthathaka lemizimba yabo
- Iingxaki zokubona (ukubona)
- Ingathi bayabhideka kwaye baye babe nobunzima bokukhumbula
- Isimo sengqondo nobuyena buyatshintsha
- Ukulibala ukwenza imisebenzi yemihla ngemihla



Ndimphatha njani umntu okhe waba nesifo sokufa icala?

- Menze umntu achithe ixesha elincinane kakhulu kangangoko ebhedini. Ukuchitha ixesha elininzi ebhedini kuza kumenza abe buthathaka ngakumbi. Kungcono umvumele athathe amaxesha okuphumla amafutshane.
- Menze umntu avuke ngexesha lakhe eliqhelekileyo kwaye ahlanjwe aphinde anxiety-iswe.
- Menze umntu afumane isidlo nosapho lonke njengesiqhelo.
- Zama ukunceda umntu alandele inkqubo eyenzelwe imihla ngemihla.
- Mkhuthaze umntu azenzele izinto. Yiba nomonde umnike ixesha elaneleyo lokugqiba imisebenzi nokuziqeqeshela yona. Ukuzenzela oko anako kunye nokuziqeqesha kwi-misebenzi yemihla ngemihla luhlobo lokuzilolonga olulungileyo.
- Khumbula ukuba umntu lo ngumntu omdala; ungaze uphathe abantu abanesifo sokufa icala ngokungathi ngabantwana.

2. Iingxaki zonxibelelwano

? Yintoni unxibelelwano?

Unxibelelwano yindlela esabelana ngayo ngolwazi singabantu ngokuthetha, ngokuthetha ngezandla (ukubonisa ngezandla), ngokubhala okanye ngezinye iindlela, kunye nokwazi kwethu ukuqonda ulwazi.

? Ingaba zeziphi iingxaki zonxibelelwano abadla ngokuba nazo abantu abakhe banesifo sokufa icala?

Abantu abakhe banesifo sokufa icala banganezi ngxaki zonxibelelwano zilandelayo:

- Ukungeva okanye ukuba nzima. Oku kungayinxalenye yokuguga kwaye akusoloko kusenzeka ngenxa yesifo sokufa icala. Umongikazi oseklinikhi unokuqinisekisa ukuba akukho nto ivala indlebe engaphandle (indawo esinokuyixilonga), efana nencindi yendlebe.
- Ukufumana ubunzima ekuqondeni
- Akakwazi kucwangcisa intetho (ukubeka izandi ezilungileyo ukwenza amagama)
- Akanako ukufumana okanye acinge amagama alungileyo
- Akakwazi ukulawula imisipha esinceda ukuba sakhe amagama, efana nolwimi nemisipha yemihlathi.
- Akakwazi ukufunda, ukubhala okanye ukuqonda imifanekiso
- Akakwazi ukuthetha ngokukhwaza

? Ndingazilungisa njani ezi ngxaki zonxibelelwano?

Xa uthetha nomntu obekhe wanesifo sokufa icala:

- Jongisa intloko yakho ngakulo mntu.
- Jonga umntu emehlweni.
- Hlalela kufutshane nalo mntu.
- Thetha ngokucotha nangokucacileyo, ngakumbi ukuba umntu udiniwe.
- Sebenzisa ilizwi lesiqhelo. Ungakhwazi.
- Phinda oko ubukuthethile ukuba umntu akakaqondi.
- Sebenzisa izivakalisi ezimfutshane.
- Phumla phakathi kwezivakalisi.
- Sebenzisa iimpawu zezandla xa uthethayo (bonisa ngezandla zakho).
- Thetha ngezinto eziqhelekileyo, nezihloko zemihla ngemihla.
- Ukuba umntu akakwazi kuthetha, buza imibuzo elula enokuphendulwa ngo-'ewe' okanye 'uhayi'.
- Ukuba akuqinisekanga ukuba umntu uqondile, mcele ukuba aphinde iinkcukacha ezibalulekileyo.

Xa umamela umntu owakhe wanesifo sokufa icala:

- Yiba nomonde.
- Jonga imilebe yomntu lowo.
- Khumbuza umntu ukuba athethe ngokucutha nangokucacileyo.
- Khumbuza umntu ukuba azikise ingqondo kakhulu xa esebenzisa amagama anzima.
- Cela ukuba umntu aphinde ukuba akuqondi. Sukwenza ngathi uyaqonda.
- Mkhuthaze umntu ukuba asebenzise amagama abahlobo nosapho.
- Mkhuthaze umntu ukuba asebenzise amagama aqhelekileyo afana no "molo" okanye 'enkosi'.
- Ukuba umntu akakwazi ukuthetha, mkhuthaze ukuba asebenzise iimpawu zezandla kwaye azikhombe izinto.

Ngokubanzi:

- Qiniseka ukuba akukho ngxolo evakalayo ngemva.
- Yehlisa umabonakude okanye unomathotholo.



Yintoni enye endingayisebenzisa ekuncedeni unxibelelwano?

A	B	C	D	E	F	G
H	I	J	K	L	M	N
O	P	R	S	T	U	V
W	Q	1	2	3	4	5
6	7	8	9	10	Yes	No

Sebenzisa ibhodi yoonobumba. Abanye abantu abanesifo sokufa icala bangakwazi ukupela oko bakufunayo



Sebenzisa itshathi (ipowusta) enemifanekiso kunye/ okanye amagama.

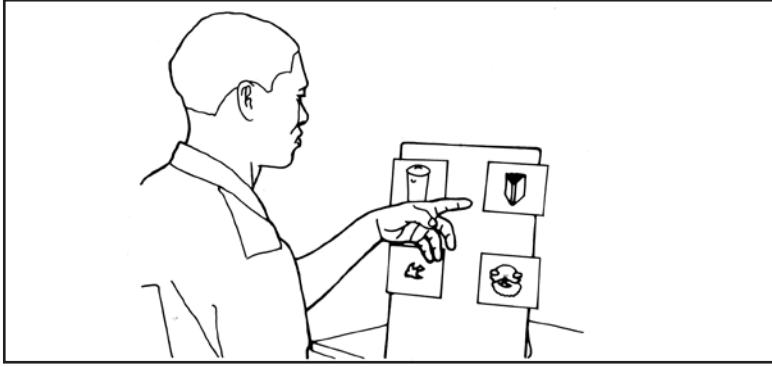

Sebenzisa imifanekiso.



Sebenzisa iimpawu zezandla.

3. **lingxaki zengqondo (ukucinga) nendlela yokuziphatha**

? Zeziphi iingxaki ezinokuba khona zengqondo nezokuziphatha kumntu obekhe wanesifo sokufa icala?

Ngenxa yomonakalo engqondweni yabo, abanye abantu abakhe banesifo sokufa icala, baba nobunzima bokukhumbula nokuqonda izinto. Abanye bakufumana kunzima ukulawula iimvakalelo nemiqaweno (iimfuno), baze baziphathe ngeendlela ezingaqhelekanga. Kodwa asingabo bonke abantu abakhe banesifo sokufa icala ababa nezi ngxaki. Ugqirha onceda ekubuyiseleni ukwazi ukusebenza angajonga ukuba umntu uyayiva na enye yezi zinto.

? Zeziphi iimpawu zezi ngxaki?

Ungaqaphela oku kulandelayo:

- Ukudideka: Umntu uye angabaqapheli abantu, angazi ukuba uphi (indawo) okanye ngubani ixesha okanye umhla.
- Iingxaki zokukhumbula okwethutyana: Umzekelo, umntu akanako ukukhumbula obe kuthethiwe kwiyure enye egqithileyo.
- Akenzi kwanto ngaphandle kokuba uyixelelwe: Umzekelo, umntu uza kuhlala ebhedini ngaphandle kokuba uxelelwe ukuba makaphakame.
- Ukunzinyelwa yimisetzenzana elula: Umsebenzi ofana nokunxiba isikipa uba nzima kakhulu.
- Ukungakwazi ukuzilawula (umzekelo ukungakwazi ukubamba umsindo, iminqaweno yezesondo okanye ukutya): Umntu angenza izinto ngaphambi kokuba azicingisise.
- Izenzo ezingalungana: Umzekelo, umntu angahleka umntu esonzakala.
- Uba neemfuno ezininzi: Umzekelo, umntu onesifo sokufa icala angafuna umhoye ngoko nangoko okanye ngalo lonke ixesha.
- Akalihoyi icala elibuthathaka lomzimba: Umzekelo, xa efuna into, akaz' ukuzama ukujonga kwicala elibuthathaka lomzimba.
- Akayiqondi imali okanye ukusebenza ngayo.
- Ukudakumba/ukuziva edakumbe kakhulu kwaye azive umoya wakhe 'uphantsi' onke amaxesha.
- Iingcaciso zokuxolisa ezinde ngokuziphatha ngendlela engaqhelekanga, kuba umntu engenalwazi lwezi ngxaki.

? Ndingajongana njani nezi ngxaki?

- Fumana uncedo lukagqirha onceda ekubuyiseleni ukukwazi ukusebenza okanye ugqirha wezengqondo weendlela zokuziphatha (Cela iikliniki yendawo yakho ikucebise ngomntu olungileyo).
- Soloko uxelela umntu onesifo sokufa icala umhla, usuku nexesha. Beka iwotshi nekhalela egumbini uze uzibonise umntu ngalo lonke ixesha.
- Landela indlela enye yokwenza yonke imihla, ngokutya, ngokuzikhathalela (ukuhlamba, ukuhlamba amazinyo, ukukama iinwele) kunye nokuphumla ngexesha elinye nangendlela enye yonke imihla.
- Qalisa ukucacisa naluphi utshintsho kwisiqhelo kuse kude lee kwixesha lotshintsho, umzekelo xa ufuna ukuya evenkileni okanye eklinikhi. Phinda ingcaciso qho.
- Sukuzivumela izinto abazenzayo ezingaqhelekanga ngenye imini uze uphinde angazivumeli ngezinye iimini. Gqiba okubona njengendlela yokuziphatha eyamkelekile, kwaye ubambebele kuyo.
- Ungamvumeli umntu akulawule ngendlela engeyiyo yokuziphatha. Umzekelo, sukunikezela kwinto efunwa ngulo mntu kuba eqhubeka nokukhwaza.
- Yiba nemigaqo ecacileyo yendlela yokuziphatha. Umzekelo, yithi: 'Musa ukukhwaza. Andiz' ukukuphendula xa ukhwaza.'
- Sukuyihlekela indlela engaqhelekanga yokuziphatha, enje ngokuthuka, nokuba iyahlekisa.
- Xelela umntu xa indlela yakhe yokuziphatha ilungile kwaye yamkelekile. Umzekelo, yithi: 'Ndiyakonwabela ukukunceda xa unombulelo.'
- Menze ancede ekwenzeni izigqibo.
- Menze umntu azenzele okuninzi ngokwakhe, kodwa uhlale kufuphi ngokwaneleyo ukuqinisekisa ukuba ukhuselekile, umzekelo kwigumbi lokuhlambela okanye ekhitshini.
- Kuqhelekile ukuba abantu abakhe banesifo sokufa icala balile lula. Ukuba ukulila akwenziwa kukudakumba, mphazamise umntu ngokumcela ukuba abale ukuya kwishumi okanye aphfumle nzulu. Sukubonisa usizi olukhulu kuba luza kwenza ukulila kuqatsele.

4. Indlela yokubeka umntu okhe wanesifo sokufa icala

Xa abantu abakhe banesifo sokufa icala behlala okanye belala ngendlela elungileyo, loo nto ingabanceda baphile kwangoko kwaye basebenze ngcono. Ukuhlala okanye ukulala ngecala elingalunganga kungenza iingxaki ezifana nokuqina, iintlungu, okanye ukuphazamisa ukuqaphela icala elibuthathaka zibe nkulu kakhulu.

? Kufuneka umntu alale njani ebhedini?

Izikhokhelo ngokubanzi:

- Sebenzisa umatraso owomeleleyo (ongathambanga kakhulu, ongaqinanga kakhulu), okanye ubeke ibhodi yokhuni efana nocango oludala phantsi komatraso.
- Udonga kufuneka lube kweli cala lomeleleyo lomntu.
- Umntu kufuneka alale ngecala elibuthathaka lomzimba ajonge ngasemnyango, ngakumabonakude, ngasesitulweni seendwendwe njalo njalo. Oku kuza kumnceda ukuba angalilibali okanye angalihoyi icala elibuthathaka.
- Umntu kufuneka achithe ixesha elincinane kakhulu kangangoko anako ebhedini.
- Xa esebhedini, umntu kufuneka alale ngecala lakhe endaweni yomqolo.
- Guqula umntu ongakwaziyo ukushukuma kwaphela emveni kweeyure ezimbini okanye ezintathu ukunqanda ukuqina kunye nezilonda zebhedini.

Indlela yokulala ngamacala omabini

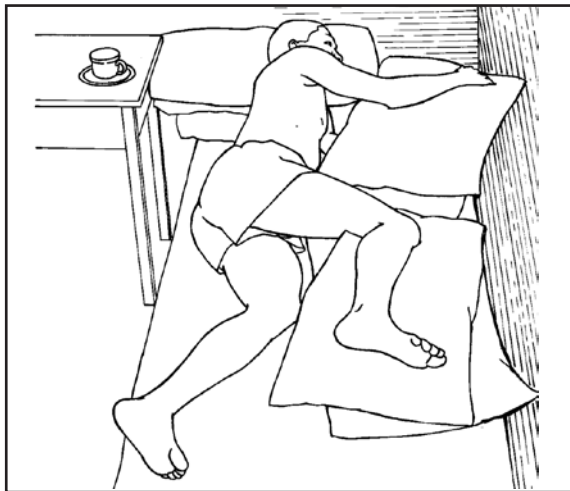

Ukulala ngecala elomeleleyo.

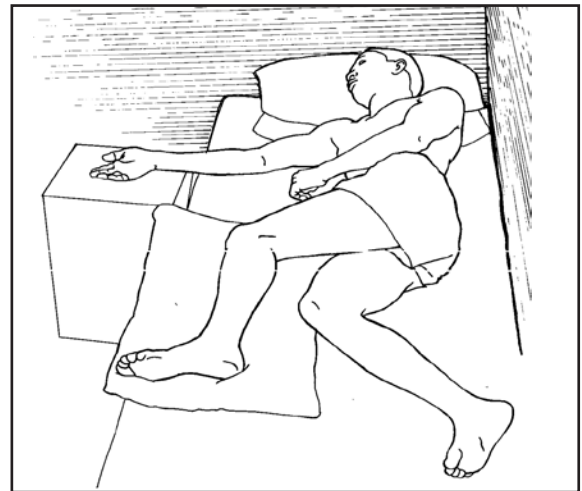

Ukulala ngecala elibuthathaka.

1. Gcina ingqiniba kude nebhedini kwindawo oziva ukhululekile kuyo.
2. Gcina isandla esibuthathaka sivulekile, singenanto.
3. Xa elele ngecala elomeleleyo, faka into phantsi kwengqiniba ebuthathaka nesandla ukuze lixhaseke.
4. Xa elele ngecala elibuthathaka, sukumvumela umntu alale phezu kwesihlanganisi sengqiniba. Beka iligxa phambi kwesifuba kwaye ungalibeki phantsi komzimba.
5. Goba idolo eliphezulu.
6. Beka imiqamelo okanye ingubo esongiweyo phantsi kwedolo eliphezulu kunye nonyawo ukuze lixhaswe ngokuphelele.
7. Ukuba ibhedini ayivulekanga ngokwaneleyo, yenza isandla nengalo ezibuthathaka ziphumle ekhadibhothini okanye etafileni esecaleni kwebhedini. Jonga ukuba ibhokisi okanye itafile ziphezulu kanye njengebhedi na – zingabi ngaphantsana okanye ngaphhezulwana.

Indlela yokulala ngomqolo

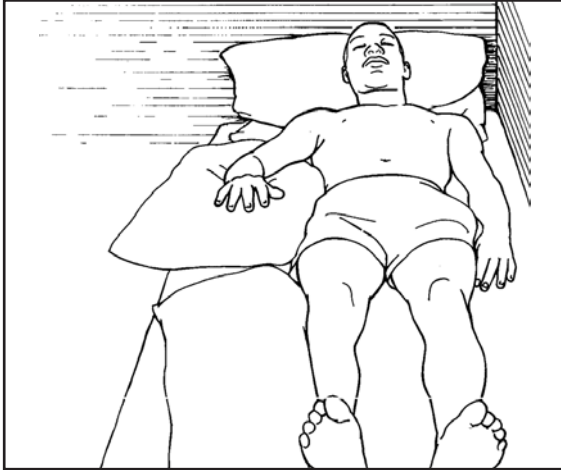

1. Umntu angalala ngomqolo wakhe ithutyana elincinane kuphela.
2. Beka itafile yasecaleni kwebhedi kwicala elibuthathaka.

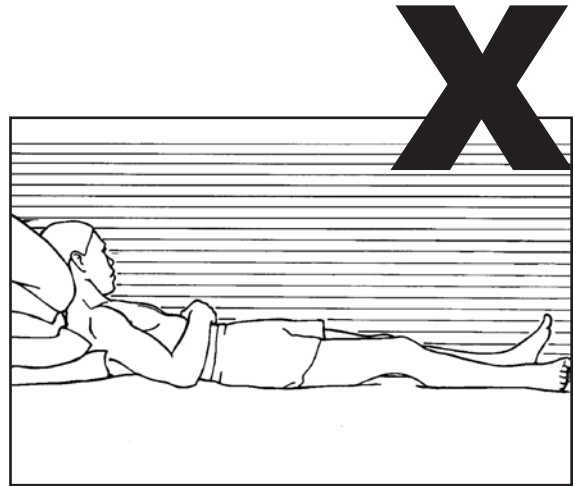

Sukuvumela umntu alale ebhedini ne-nqwaba yemiqamelo engxalwe emva komqolo wakhe.

Oku kungenza:

- Izilonda zebhedi
- Iingxaki zokuphefumla
- Iingxaki zokuginya
- Ukuqina okungaphaya engalweni nas-
emlenzeni
- Umqolo ogobekileyo okanye intloko
eye phambili

Indlela yokuhlala ebhedini (kuphela ukuba umntu akakwazi ukuphuma ebhedini)

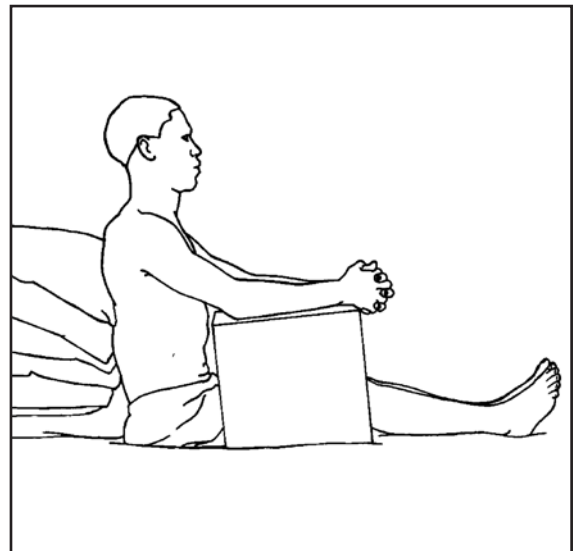
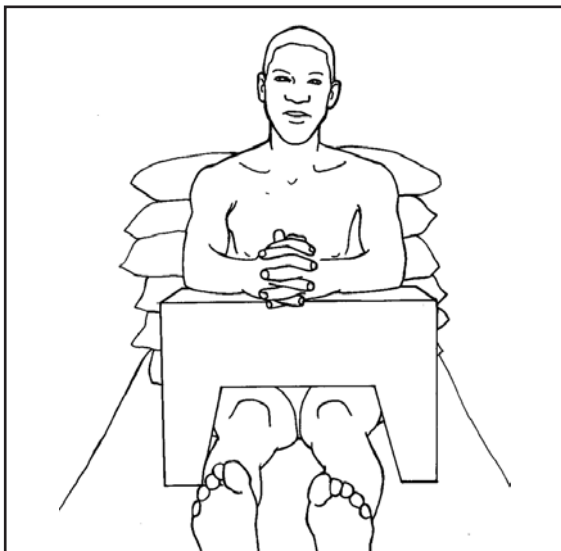

1. Menze umntu ahlale nkqo imilenze yolulwe iye phambili. Ukuba ubeka umqamelo phantsi kwamadolo kungavakala kamnandi kakhulu.
2. Kufuneka ukuba umqolo ube ngasedongeni okanye ngasebhodini yokungqiyamisa intloko. Ukuba umntu akanako ukusondezwa kwindawo ephezulu yebhedi, beka isitulo phakathi kwakhe nebhodi yokungqiyamisa intloko.
3. Beka imiqamelo okanye ingubo esongiweyo emva komqolo ukumxhasa.
4. Yenza itafile ebekwa emathangeni ngebhokisi (jonga ngezantsi), apho kungaphumla khona iingalo.
5. Umntu kufuneka ahlale ngolu hlobo kuphela ukuba akakwazi kuphuma ebhedini.

Indlela yokwenza itafle ebekwa emathangeni ngekhalibhodi

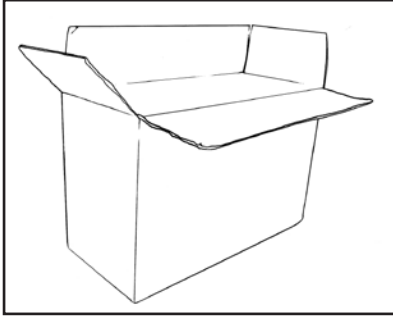

1. Sebenzisa ibhokisi eyomeleleyo nevuleke ngokwaneleyo ukuba kungene amathanga omabini kakuhle.

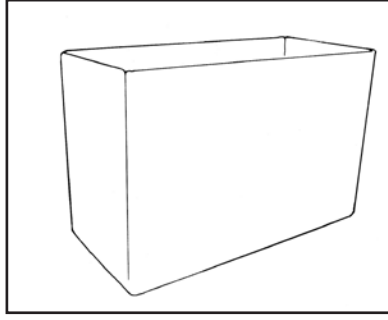

2. Sika amacala ajingayo okanye uwancamathisele emacaleni ukuqinisa amacala ebhokisi.

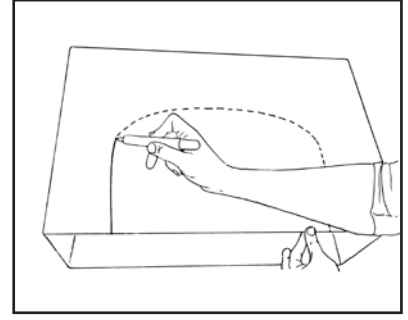

3. Zoba igophe kumacala omabini ebhokisi. Oku kukwenza isithuba esivulekileyo semilenze ukuba ingene ngaphantsi kwetafile, ke ngoku qiniseka ukuba sikhulu ngokwaneleyo.

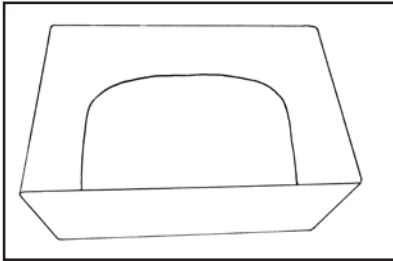

4. Kufuneka ukuba igophe libonakale ngolu hlobo xa sele ligqityiwe.

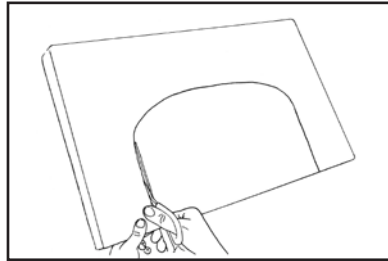

5. Ngoku sika igophe emg-ceni.

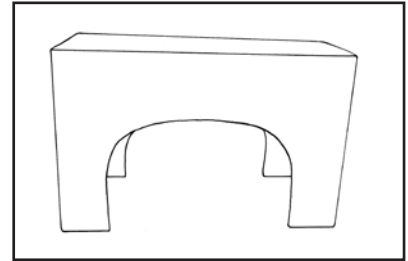

6. Itafle yakho ebekwa emathangeni ngoku iku-lungele ukusetyenziswa.



Ingaba kufuneka umntu ahlale njani?

Ingaba kuhlalwa njani esitulweni okanye kwisitulo esinamavili

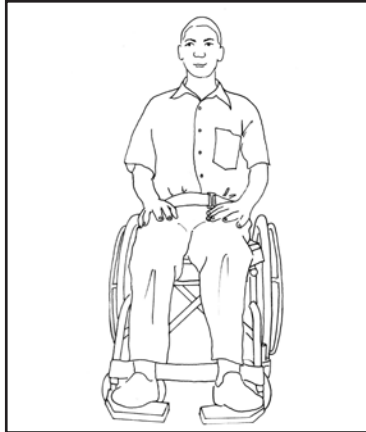
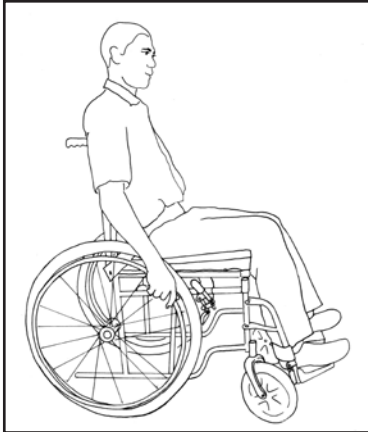

Soloko usebenzisa umqamelo wesitulo esinamavili kwisitulo esinamavili.

Izikhokhelo ngokubanzi:

- Isitulo kufuneka sicutheke kangangoko sinako ukuze umntu akwazi ukwanela esitulweni ngokukhululekileyo.
- Isitulo masiqine. Sebenzisa isitulo esinomva oqinileyo kunesitulo esilula (isitulo esingxaliweyo).
- Umntu makahlale nkqo kangangoko anako, umqolo wakhe wayame ngokuthe nkqo kumva wesitulo.
- Kufuneka ukuba umzantsi womntu wayame kumva wesitulo. Ukuba akaziva ezinzile okanye ekhululekile xa umva ukude lee ngemva, faka umqamelo omncinane kumva wesitulo.
- Beka iinyawo zomntu phantsi okanye kwisiphumzi seenyawo ukumxhasa. Ukuba iinyawo azifiki phantsi, zixhase ngebhokisi yamaplanga, ngenqwaba yamaphephandaba, okanye yeekhalibhodi ezidityanisiweyo.

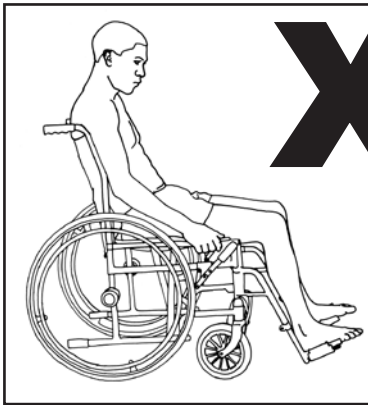

Xa abantu abakhe banesifo sokufa icala bengahlali ngendlela elungileyo, oko kungadala:

- Ukungakhululeki okanye iintlungu
- Ukuqina komlenze okanye kwengalo ebuthathaka
- Ukudumba kwesandla nengalo
- Ukutyibilika uphume esitulweni



Zingakunqanda njani iintambo ukutyibilika uphume esitulweni?

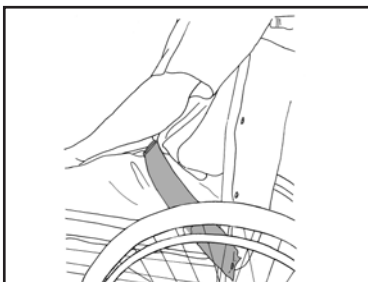

Bophelela umntu emady-wantsini, ngentambo esuka kwiikona ezisemazantsi omva wesitulo.

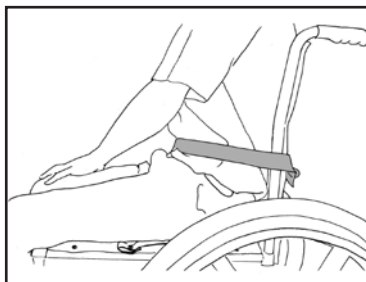

Sukumbopha esiswini okanye esifubeni.

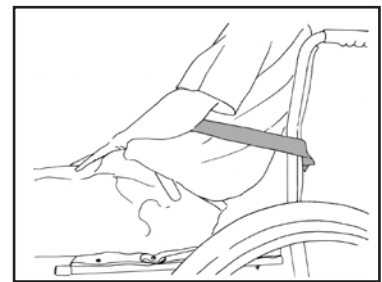

Umntu useza kutyibilika ukuba usebenzisa intambo ejikeleza isisu okanye isifuba.



Ingancanyathiselwa njani ibhanti esongelwayo esitulweni?

Kwisitulo esinamavili

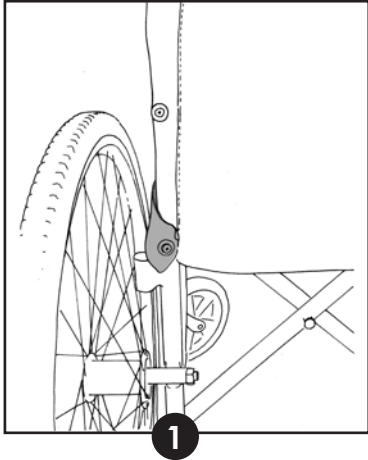

Qhobosa ibhanti kwisakhelo sesitulo esinamavili ngokusebenzisa isikrifu esisezantsi somva wokwayama wesitulo esinamavili okanye isikrifu esisemva kwisihlalo.

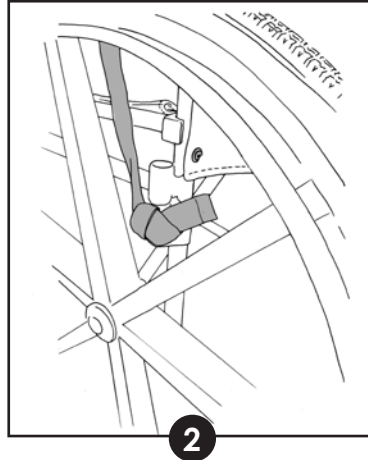

Usenokuyibopha ibhanti kwindawo ethe nkqo yesakhelo sesitulo esinamavili, kanye ngaphantsi kwesiphelo esisemva sesihlalo.

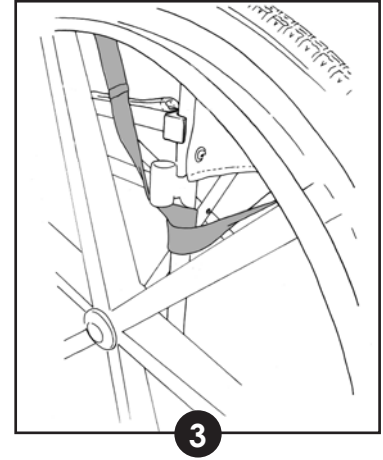

Ukuba usebenzisa ibhanti ende ebophelela phambi komntu, yihake kwaye uyijikelezise kwindawo ethe nkqo yesakhelo sesitulo esinamavili kwelinye icala, ngaphantsi kwesiphelo esisemva sesihlalo.

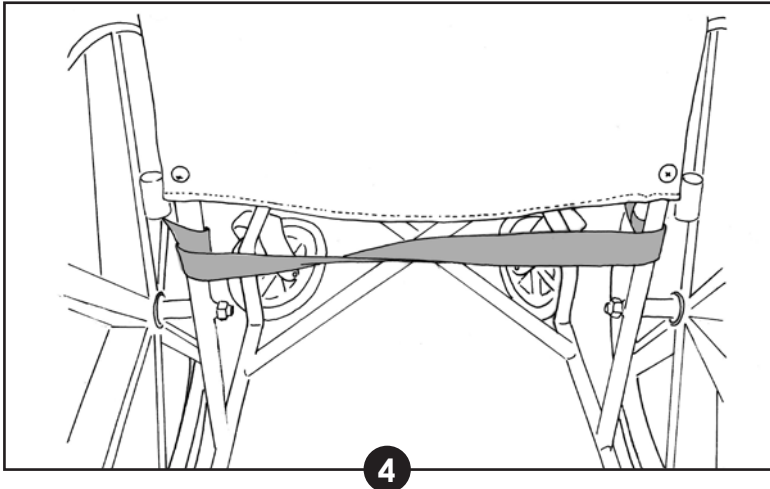

Ke ngoku yijikelise uyise emva kwelinye icala lesakhelo nangaphantsi kwesiphelo esisemva sesihlalo.

Kwisitulo esiqhelekileyo

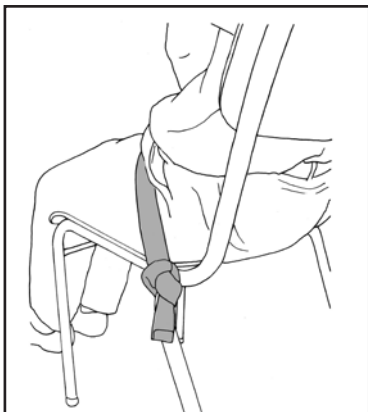

Bophelela ibhanti kwiinyawo ezingemva zesitulo, kanye ngaphantsi kwesihlalo.



Ingaba ndingazixhasa njani iingalo nezandla?

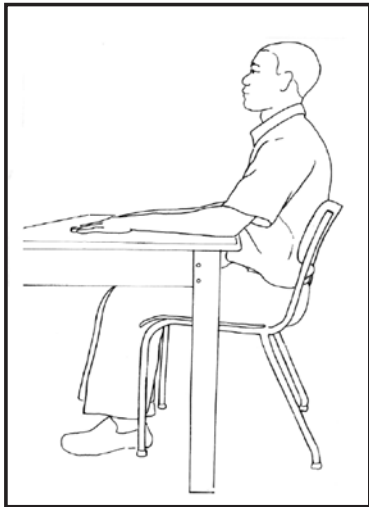

Etafileni.

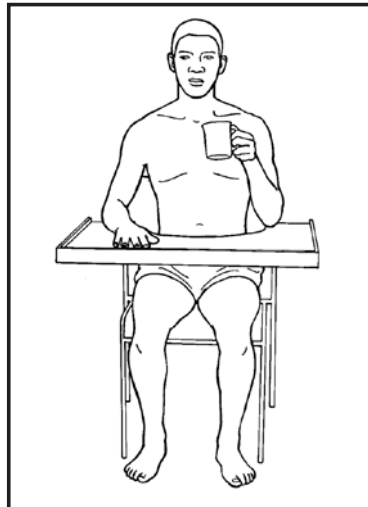

Kwitreyi yethanga.



Musa ukufaka
ingalo esilingini.

Izikhokhelo ngokubanzi:

- Soloko uqinisekisa ukuba ingalo yonke, kunye nengqiniba nesandla ziphumla etafileni, kwisiphumzi sengalo okanye kwitafle yetreyi. Jonga umzekelo wetafle yetreyi ngezantsi.
- Isandla kufuneka sivuleke ize intende yesandla ibekwe phantsi ithi tyaba etafileni, kwisiphumzi sesandla okanye etreyini.
- Sukusebenzisa imiqamelo kwithanga ukuxhasa ingalo ebuthathaka ngexesha umntu ehleli. Oku akuniki nkxaso eyaneleyo, kwaye isandla singadumba okanye ilungu lengqiniba lingatsaleka livuleke. (Ukukhathalelwa kwegxalaba kucaciswe kwiSahluko sesi- 6.)

Umzekelo wetafle eyitreyi

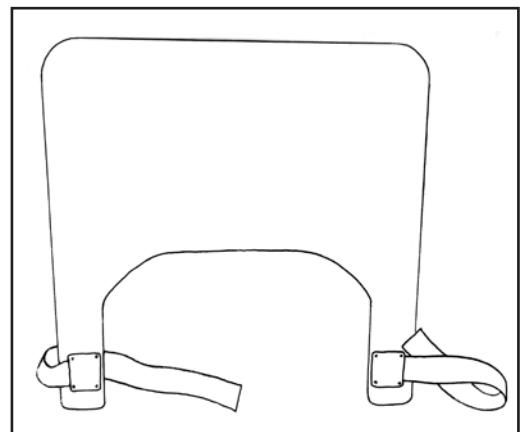
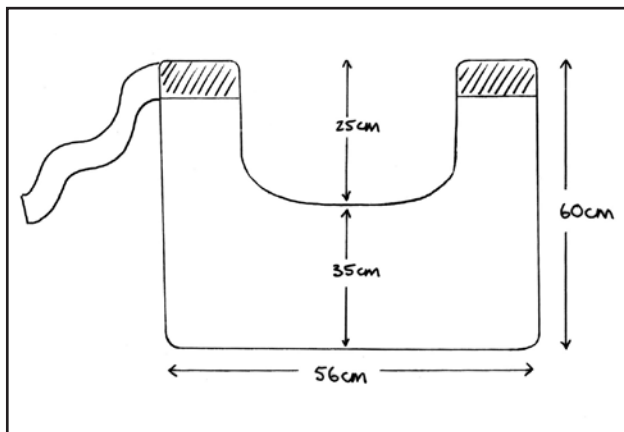

Umntu angenza itafle eyitreyi ngebhodi eqinileyo etyebileyo okanye ngeplayi (plywood) ebhityileyo. Khuhla umgangatho nemiqumkumbelo yetreyi eyitafle. Umphezulu ungapeyintwa okanye uvanishwe ukukhusela itafle ekumoshweni ngamanzi nasekwenzeni lula ukuyicoca. Ubukhulu bungalungiselelwa ngokomlinganiselo wetafle nowomtu.

5. Ukutya, ukuginya kunye nonakekelo lwamazinyo / okanye unakekelo lomlomo



Ndingamnceda njani umntu ekubeni atye?

Umntu kufuneka enze oku kulandelayo:

- Ahlale ngeempundu kwizidlo zonke.
- Ahlale nkqo.
- Agcine intloko iphambilana.
- Ajonge ekutyeni.
- Aphumze iingalo etafileni.
- Agcine iinyawo zihleli bhaxa kwindawo yokuphumza iinyawo yesitulo esinamavili okanye phantsi emgangathweni.
- Atye kancinane kwaye asele kancinane.
- Ase ukutya okuhlafuniweyo embindini wolwimi phambi kokuginya.
- Asele kwiglasi egcweleyo okanye asebenzise istro ukunqanda intloko ukuba ibuyele emva.
- Ahlale nkqo ubuncinane imizuzu engama-20 – 30 emva kokutya ukuze ukutya kwetyiswe.

Umnonopheli kufuneka enze oku kulandelayo:

1. Ahlale phambi komntu, okanye ame ecaleni komntu.
2. Xa umile, beka olunye unyawo lwakho kwisixhasi esisezantsi, esifana nebhokisi yamaplanga okanye isitulo esiphantsi seplanga.
3. Soloko ugcine umqolo wakho uthe nkqo; sukuwugoba.
4. Sebenzisa ingalo yakho ekufutshane nalo mntu ukuxhasa intloko yakhe.
5. Beka ukutya phakathi kwamazinyo kwicala elomeleleyo lomlomo walo mntu.
6. Mnike ukutya okungamanzi okungqumbululu kunye nokutya okuthambileyo. Kulula ukuginya iyogathi, ikhastadi kunye nesuphu engqumbululu.



Ukuba umntu usoloko ekhohlela okanye ekhameka, cela ukubona ingcali yokunyanga ukuthetha. Unokujonga ukuba umntu uyakwazi na ukuginya ukutya kunye neziselo ngokukhuselekileyo, aze anike ingcebiso efunekayo ukuphucula ukuginya.

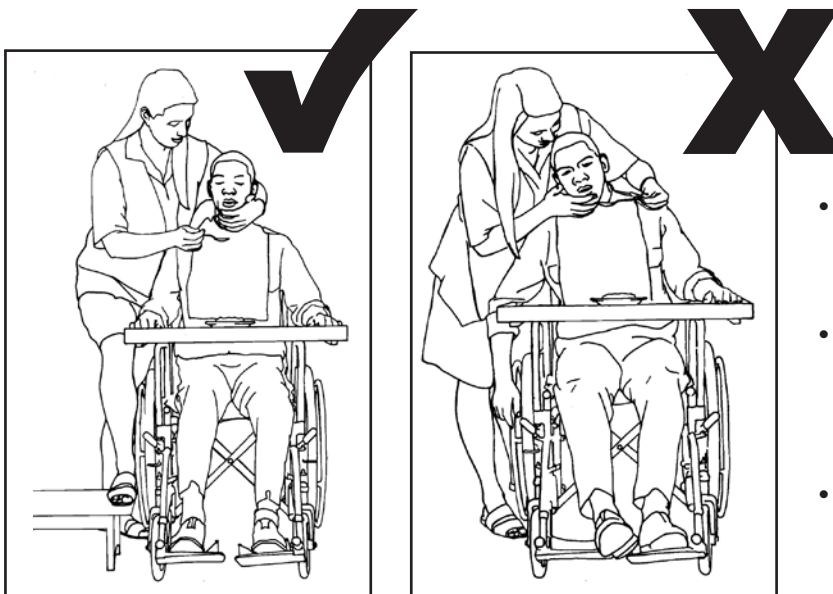

- Sukuvumela intloko yomntu ithambekele ecaleni okanye ngemva.
- Sukuyeka ingalo ijinge okanye iwe etafileni, kwisiphumzi sengalo okanye kwitreyi yamathanga.
- Ungaziyeki iinyawo zityibilike kwisiphumzi seenyawo sesitulo esinamavili.



- Umntu akufuneki azise umqala wakhe kunye nentloko yakhe phezulu okanye phambili ukuze afikelele ekutyeni. Oku kwenza nzima ukuginya.
- Bamba icephe kanye ngaphambi komlomo.
- Yisa icephe emlonyeni womntu. Akufuneki ukuba umntu ashukumise intloko ukuze afikelele ecepheni.

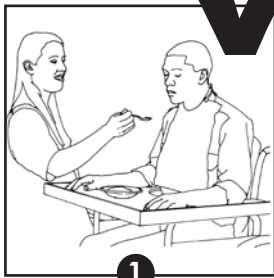

1

Beka icephe kumphambili wolwimi.



2

Ukuba ulwimi luyaphuma, lutyhalele ezantsi kancinane ngecephhe.

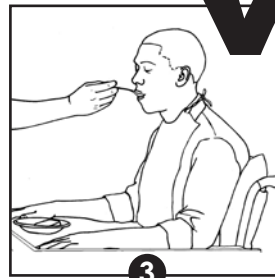

3

Qinisekisa ukuba imilebe iyavaleka ecepheni.



4

Beka ukutya phakathi kwamazinyo kwicala elomeleleyo lomlomo.



Ingaba ndingamnceda njani umntu ekubeni asele?



- Beka iminwe yakho kwisidlele somntu, kwisilevu nakumhlathi ongezantsi ukumnceda avale imilebe okanye umlomo. Qaphela ukuba intloko akuyithambekelisi ngasemva.



- Xa usebenzisa istro, soloko usifaka kwicala elomeleleyo lomlomo ngasesidleleni.



- Ukuba umntu akanako ukusela kwikomityi okanye asebenzise istro, sebenzisa isirinji ngaphandle kwenaliti ukufaka ukutya okanye iziselo ezingamanzi emlonyeni.
- Sibeke kwicala elomeleleyo lomlomo, ngasesidleleni. Tsazisela ulwelo kwicala lesidlele.



Ndingamnceda njani umntu osokolayo ekufakeni ukutya ecepheni/efolokhweni ngesandla esinye?

Sebenzisa ipleyitii enzulu okanye isixhasi sepleyiti (uhlobo loku 'misa') ukunqanda ukutya ukuba kungatyibiliki kuphume etafileni

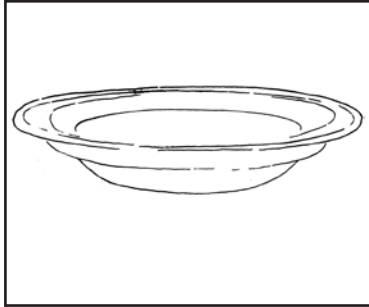

Ipleyiti enzulu.



Ipleyiti enesixhasi sepleyiti ethengwe evenkileni.

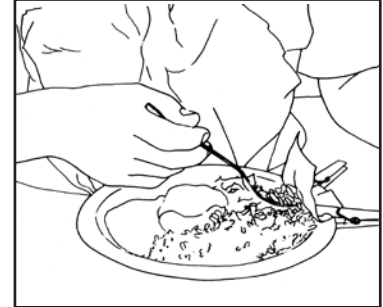

Isixhasi sepleyiti esenziwe ekhaya.

Ingaba usenza njani isixhasi sepleyiti



1 Thabatha ilitha okanye iilitha ezimbini zebhotile yobisi okanye yejusi engenanto.



2 Zoba umgca othe tyaba oziisentimitha ezi-5 ukususela kumphantsi webhotile (uhamba njalo ngomphantsi).

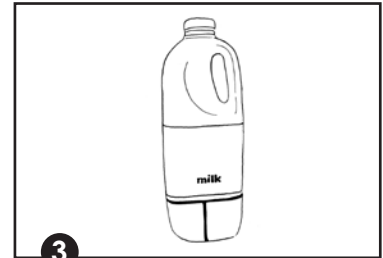

3 Ngoku zoba umgca uhamba kulo mgca othe tyaba, unqumla kumphantsi webhotile.

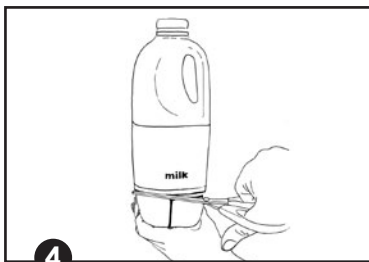

4 Sika kumgca othe tyaba ukususa umphantsi webhotile.



5 Susa umphantsi.

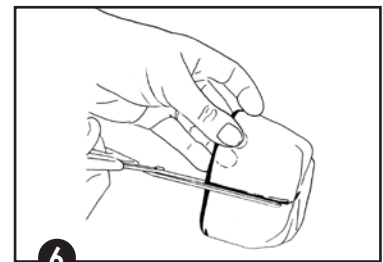

6 Sika umphantsi ube ngamacwecwe amabini kumgca ohamba embindini.

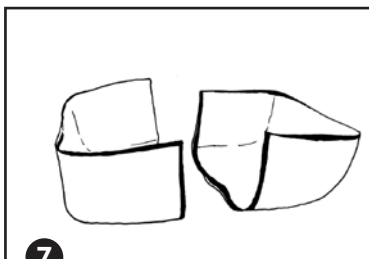

7 Ngoku unamacwecwe amabini azimeleyo omphantsi webhotile.

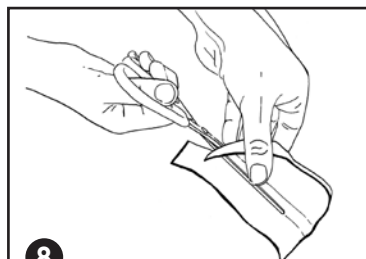

8 Sebenzisa elinye lala macwecwe. Sika elinye icala libe banzi njengomqokumbelo wepleyiti.



9 Ncamathisela kumqokumbelo wepleyiti iiphegi zempahla.

Indlela yokwenza ibhodi yokuqabela nokuxobulela yabantu abanokusebenzisa isandla esinye kuphela



Ukuqaba ngesandla esinye



Ukuxobula ngesandla esinye

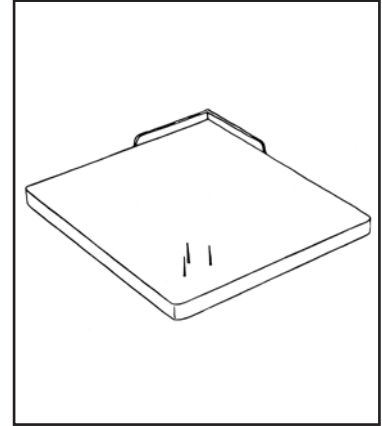

Ulungiselelo lwebhodi yokuqabela nokuxobululela yabantu abanokusebenzisa isandla esinye kuphela

Udinga:

- Iceba lokhuni, elifana nebhodi yesonka endala, elili-15 cm x 15 cm
- Izikhonkwane ezinde ezintathu ezisisi-8 cm ubude
- Izikhonkwane ezine ezimfutshane
- Imicu emibini yesinyithi okanye iplastikhi eyomeleleyo, esisi-6 cm ubude nende nge-1 cm kunokhuni.

Inkqubo:

1. Bethelela izikhonkwane ezinde ezintathu kwenye ikona yokhuni ukwenza unxantathu okanye isikwere. (jonga umfanekiso)
2. Sebenzisa izikhonkwane ezimfutshane ukuncamathisela isinyithi okanye imicwe yeplastiki kwelinye icala lekona elijongene nezikhonkwane. Kufuneka imicwe ivele kangange-1 cm ngaphezu kwebhodi

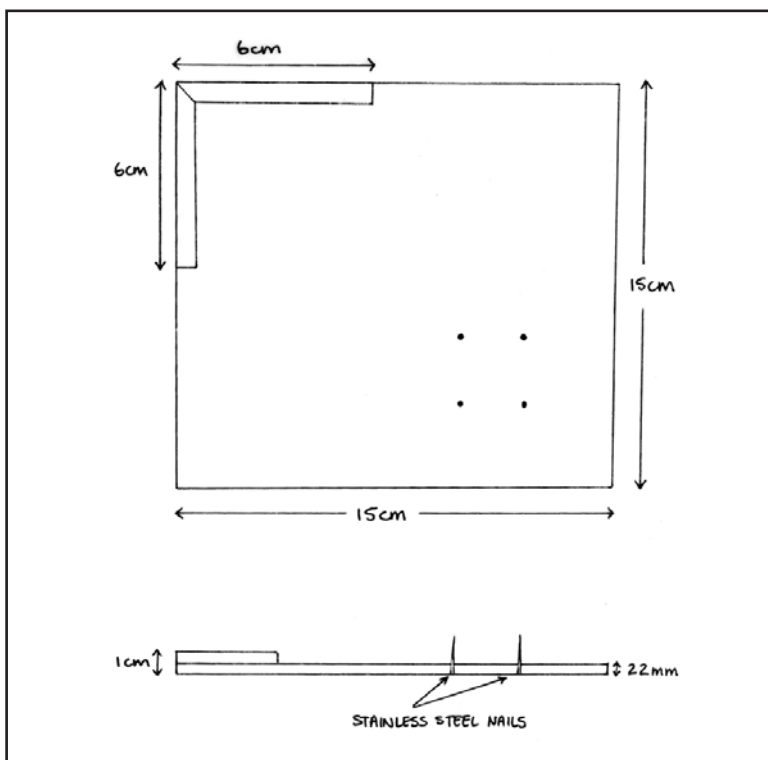

Imilinganiselo neenkukacha zobucukubhode zebhodi yokuqabela nokuxobulela

Indlela yokwenza indawo yokubamba enkulwana ukuba umntu uyasokola ekubambeni isiphatho esibhityileyo.

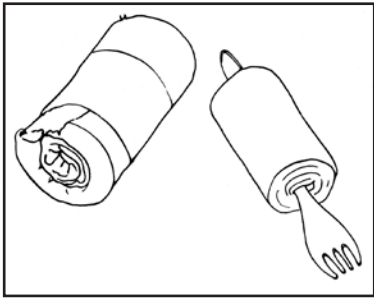

Udinga:

- Icephe okanye ifolokhwe
- Malunga nesi-6 cm x 10 cm semfunxa exinene kakhulu (kuxhomekeka kubude becephe kunye nokuba masibe sikhulu kangakanani isiphatho)
- Iplastara/neteyiphu engumbhobho

Inkqubo:

1. Jijela irabha engathi yimfunxa kumqheba wecephe okanye wefolokhwe ukwenza indawo yokubamba ibe nkulwana.
2. Bophelela uye ezantsi ngeplastara/neteyiphu engumbhobho.



Ingaba ndingamnceda njani umntu ekubhrasheni amazinyo akhe?



1. Menze umntu ahlale phambi kwesipili.
2. Umntu kufuneka ahlale nkqo.
3. Gcina intloko ime nkqo.
4. Yenza ingalo ebuthathaka iphumle etafileni okanye kumphetho wesitya sokuhlambela.
5. Yima emva komntu kwaye ujonge esipilini.



Sukuthambekisela intloko yomntu emva okanye ecaleni.

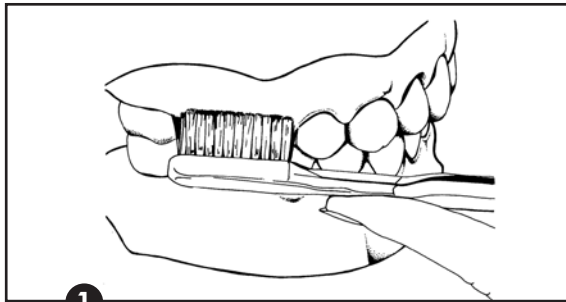

1

Bamba ibrashi ibe kwi-engile engama-45° (ithambekele kancinane) kwiintsini nas-emazinyweni omntu.

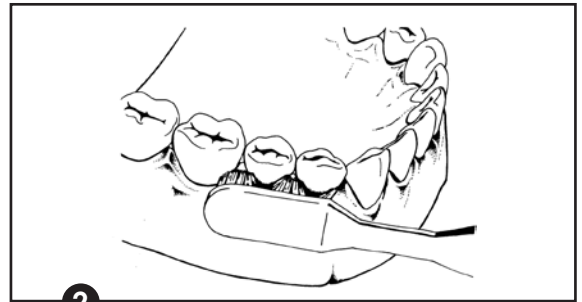

2

Brasha ngemijikelo emincinane.

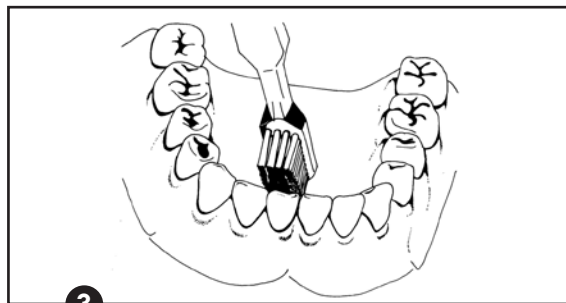

3

Brasha ngaphakathi nangaphandle kwamazinyo.

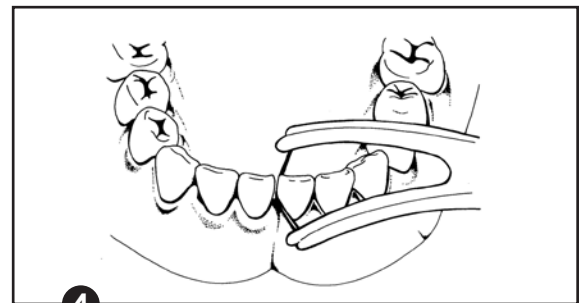

4

Sebenzisa isiqulathi somsonoto wesilikam ukucoca phakathi kwamazinyo. Jonga umzekelo wesiqulathi somsonoto wesilika (iflosi) ngezantsi.



Ndingamnceda njani umntu ekubambeni ibrashi yamazinyo ukuba isandla sibuthathaka kakhulu?

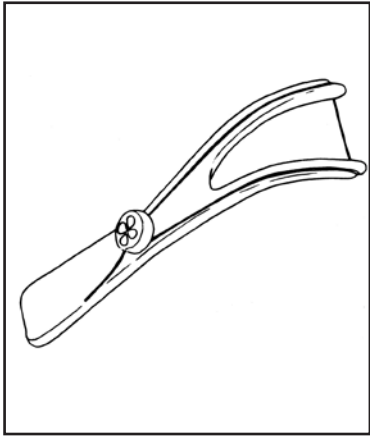

Umzekelo wesiqulathi somsonoto wesilika.

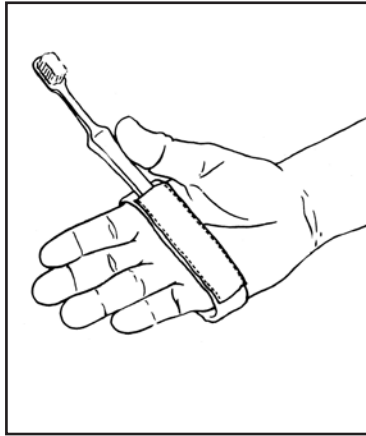

Umzekelo wesiqulathi sebhrashi.

Isiqulathi esilula sebhrashi singenziwa ngelaphu elomeleleyo, elinganwebekiyo elifana nelaphu le-upholstery okanye ibhanti eqinileyo esetyenziswa nasekuqukumbeleni. Yenza intambo eqhagamshelaka esandleni ngeVelcro. Thungela impokotho kwindawo yentende yesandla apho ibrashi yokuhlamba amazinyo ingangena khona. Kufuneka ukuba impokotho ingene kakuhle ebhrashini yokuhlamba amazinyo ukuze ibhrashi yokuhlamba amazinyo ihlale ingagungqi.

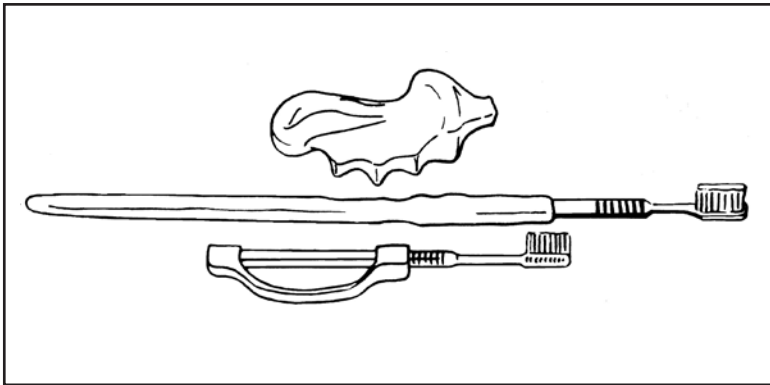

Ezinye iindlela zokuphucula isiqulathi sebhrashi ziquka:

- Sebenzisa isiqulathi sebhrashi esikhulwana. Ungenza isiqulathi sebhrashi ngokwakho njengokuba kucacisiwe ngaphambili, okanye usithenge kwivenkile ethile.
- OKANYE
- Sebenzisa imiqheba emidana. Oku kusebenza kakuhle kumntu osokoloya ekuphakamiseni izandla zakhe ziye phezulu ngokwaneleyo.
- OKANYE
- Thenga isiqulathi sebhrashii kwivenkile ethile.

6. Ukhathalelo lwamagxa

Abantu abaninzi abakhe banesifo sokufa icala baye babe neligxa elibuhlungu kunye/ okanye eliqinileyo. Ungakunqanda oku ngokubamba eli ligxa ngendlela elungileyo.

? Yeyiphi indlela elungileyo yokulawula ingalo yomntu ebuthathaka okanye ekhubazekileyo?

- Xhasa umntu ngebhokisi yokuxhasa iimbambo ukumnceda ukuba aziqengqe, ahlale nkqo, njalo njalo.
- Sukutsala ingalo yomntu.
- Ngaphambi kokuba uhlambe okanye unxibise ingalo ebuthathaka, soloko uqinisekisa ukuba igxalaba likhululekile (likhululekile ukuba lishukume).

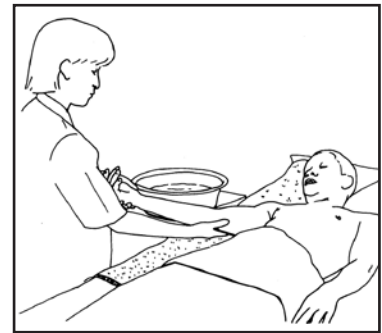
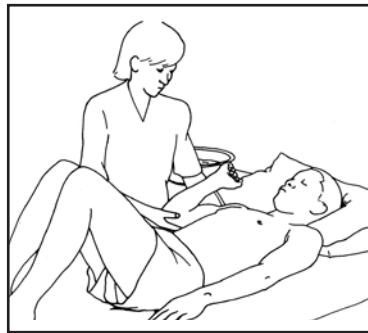

1. Goba isandla sakho sibe ligwegwe kwigxalaba elikwicala elibuthathaka.
2. Tsala igxalaba ngononophelo liye emacaleni naphambili.
3. Phinda oku amaxesha ambalwa lide igxalaba lizishukumele ngokukhululekileyo.
4. Gcina igxalaba lijonge phambili.
5. Bamba ingalo kanye ngaphezu kwengqiniba uze ujike ingalo nesandla ngononophelo ziye ngaphandle.
6. Yeka ukuba umntu uva iintlungu.
7. Ungabambi ingalo okanye ingalo engezantsi kuba oku kungenza iintlungu okanye umonakalo engqinibeni.
8. Xa ingalo ishukuma ngokukhululeka, ngononophelo thatha ingalo yomntu engentla kwengqiniba uze ususe ingalo iye kude nomzimba.
9. Yolula ingqiniba.
10. Ngoku phakamisa ilungu lengqiniba ngononophelo kwaye/ okanye ulise ecaleni ukuze azinxibise kwaye azihlambe.



Ungaze utsale ingalo ebuthathaka.

? Ndingalithini igxalaba xa ndiguqula umntu ebhedini?

- Ngaphambi kokuba uguqule umntu aye kwicala lakhe elibuthathaka, khulula igxalaba ngendlela efana nale ecaciswe ngentla, kwaye ulitsalele phambili (kwiimbambo).
- Xhasa ingalo negxalaba kwindawo ephambili. Ngoku usabambe loo ndawo, umntu angaqengqelekela kwicala elibuthathaka.
- Sukuvumela umntu alale kwilungu legxalaba.

? Ndingazixhasa njani iingalo ngexesha umntu esahleli?

- Xhasa ingqiniba kanye ecaleni komzimba ukugcina amalungu engqiniba kwindawo ekhuselekileyo. Isixhaso kufuneka sibe phezulu ngokwaneleyo ukuze ingalo ihlale iflethi/ithe tyaba.
- Ukuba isixhaso sisezantsi kakhulu okanye sikude kakhulu emzimbeni, ithambo lengalo ephezulu lingaphuma kwisiseko kwaye ilungu lomzimba liza kutsaleka livuleke lize lenze iintlungu.

? Kutheni kufuneka ndingasebenzisi isilingi?

Isilingi esenza ingalo iphumle phambi komzimba siza kwenza ukuqina kube ngaphezulu, siza kwenza ukuba imisipha esemagxeni inciphe, kwaye siza kwenza kube nzima ukushukumisa isandla siye kwicala lomzimba. Oku kuza kwenza ukuba imisipha ityeke xa ingalo iphakanyiselwa ukunxityiswa okanye ukuhlanjwa. Isilingi singenza nesihlahla sigobe kwaye siqine, kwaye singenza nesandla sidumbe.

? Kutheni kufuneka ndingaze ndimnike umntu ibhola ukuze ayicudise?

Ungaze unike umntu ibhola ukuba ayicudise ngesandla esibuthathaka kuba oku kuza kwandisa ukuqina kwesandla kwaye kuza kwenza ukuba kube nzima kakhulu ukuvula iminwe ukuze ahlambe okanye osule isandla.

? Yeyiphi indlela elungileyo yokulolonga igxalaba?

Ulolongo olulula lokugcina igxalaba, ingqiniba, kunye nesihlahla zishukuma lula nakhululekileyo

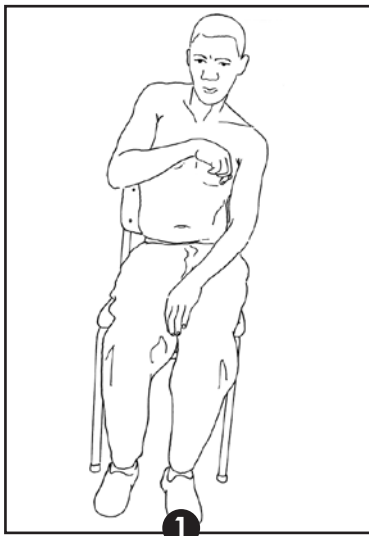

1

Sebenzisa isitulo esomeleleyo esinesixhaso esilungileyo somqolo. Menze umntu ahlale ngendlela yokuba iimpundu zakhe zifikelele kumva wesitulo zize neenyawo ziphumle phantsi emgangathweni.



2

Ngoku yenza umntu agobele phambili kwaye azise ingqiniba ebuthathaka ngononophelo kumphakathi wedolo elibuthathaka.

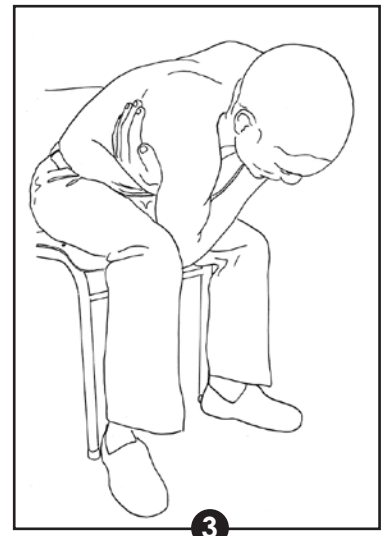

3

Umntu ubamba igxalaba elibuthathaka ngesandla esomeleleyo ngokufikelela phantsi kwekhwapha okanye ngaphaya kweligxa. Umzimba ophezulu utsalwa ngononophelo uye kwidolo elomeleleyo. Phinda lide igxalaba liye phambili kangangoko linako.

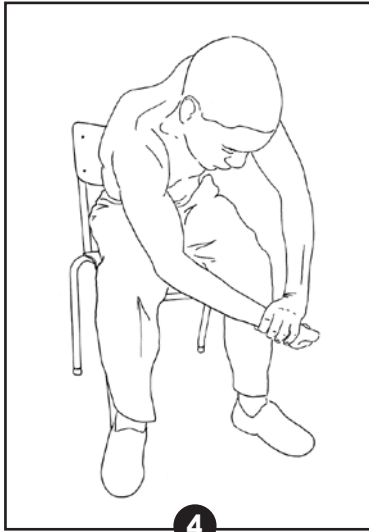

4

Umntu ugcina umzimba wakhe ugobele phambili, uthabatha ingalo ebuthathaka ngesihlahla, aze aqalise ngobunono ukwelula ingqiniba ngaphaya kwedolo.



5

Yolula kancinane ingalo iye ezinyaweni ide ingqiniba ithi nkqo kangangoko.

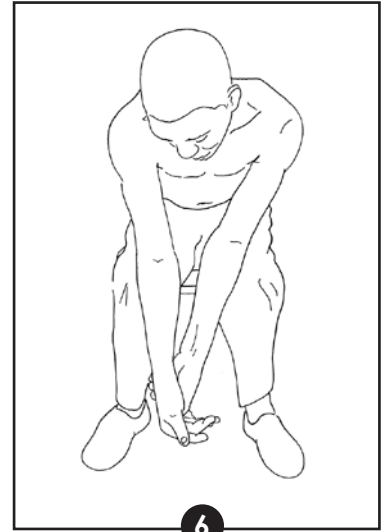

6

Ukuba kuyenzeka, vumela umntu azolule ukuya phantsi okanye emgangathweni.

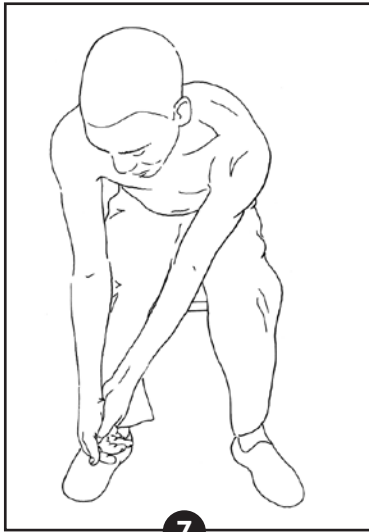

7

Ngoku vumela umntu ukuba atyibilikise iingalo ziye ecaleni zide zibe kwicala ngalinye ledolo elibuthathaka. Izandla kufuneka zihlale zikufutshane kangangoko kunye nonyawo.

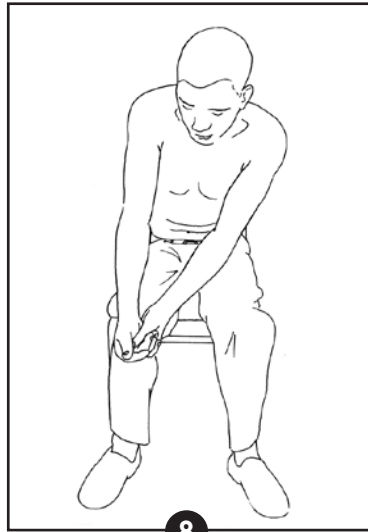

8

Qalisa ukutyibilikisa izandla ziye phezulu emlenzeni ongezantsi obuthathaka.

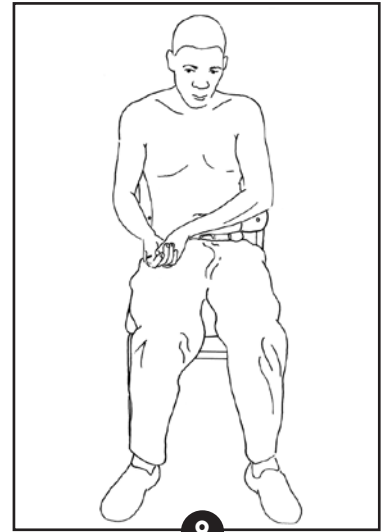

9

Qhubeka nokutyibilikisa izandla ziye phezulu kwithanga elibuthathaka.

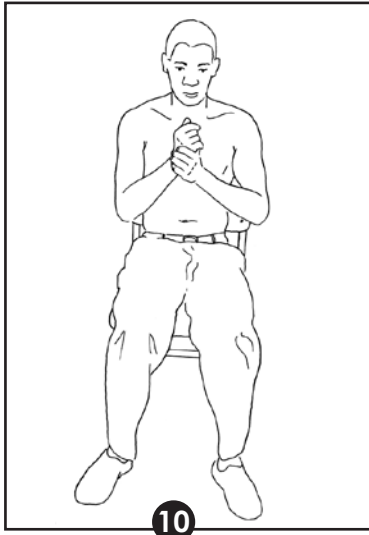

Zisa izandla kumbindi womzimba uze uzityibilikise ziye esifubeni.

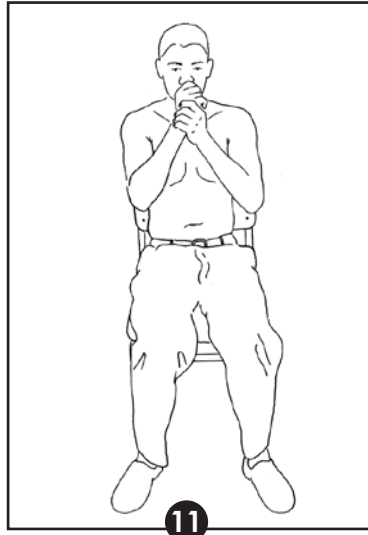

Umntu ngoku utyibilikisa izandla zakhe ukuze zifikelele empumlweni. Qhubeka kuphela ukuba akukho zintlungu.

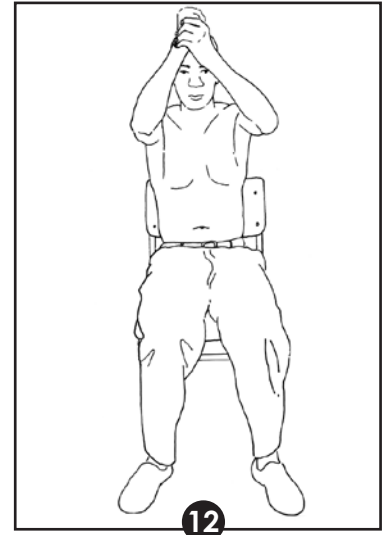

Tyibilikisa ude ufikelele kumphezulu wentloko. Qhubeka kuphela ukuba akukho zintlungu.

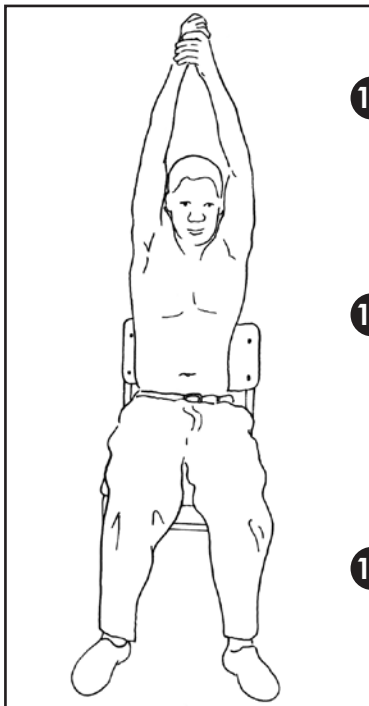

13 Ukuba igxalaba alibuhlungwanga okanye aliqinanga, umntu kufuneka olule iingalo ziye phezulu kangangoko ngaphandle kokwenza iintlungu.

14 Phinda olu lolongo kahlanu ukuya kwishumi ngeseshoni, ubuncinane kanye ngemini. Menze umntu azame ukolula amalungu aye kudana ngexesha ngalinye ezilolonga.

15 Sukuqhubeka ngokolula ukuba kukhona iintlungu. Ukuba kubuhlungu, yeka ukwelula uze uphinde amanye amanyathelo okuzilolonga ebenikhe nawenza ngaphambili.

7. Ukugqithisela ebhedini

Imithetho-siseko yokugqithisela ngokubanzi:

- Ungaze utsale ingalo okanye umlenze.
- Soloko ucacisela umntu ukuba ufuna ukwenza ntoni.
- Cela umntu ukuba ancede kangoko anako.
- Hlalela kufutshane nomntu ngaphandle kokumtyhala.
- Goba amadolo akho kwaye ugcine umqolo wakho uthe nkqo.



Abantu ababini bangamgqithisela njani umntu ongakwaziyo kwaphela ukuzigqithisela ngokwakhe?

Kwibhedi ephantsi

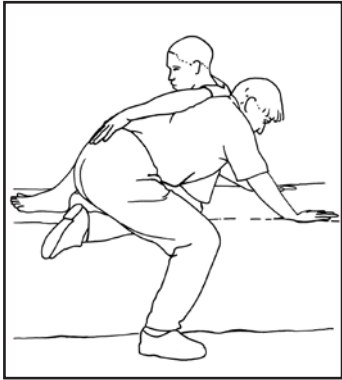

1. Zisa umntu kwindawo yokuhlala kwaye ugobe amadolo akhe.
2. Abanonopheli bobabini bajonga emntwini baze bagobele amadolo abo kufutshane kakhulu kuye ukuze baguqe kwicala ngalinye lebhedi.
3. Abanonopheli babeka amagxa abo kumacala omabini omzimba, ngaphantsi nje kwamakhwapha. Umntu angabeka ingalo yakhe emva komnonopheli.
4. Abanonopheli kufuneka bathathe ingqalelo bangatyhilizeli amagxa abo emakhwapheni.
5. Abanonopheli bayazixhasa ngezandla zabo kude le emntwini.
6. Abanonopheli basongela ezinye izandla zabo kwimilenze eph-ezulu yomntu kufutshane nomzantsi.



7. Abanonopheli bobabini bacudisela amagxa abo ngas-emzimbeni womntu.
8. Abanonopheli bavala iingalo zabo ezisondele kakhulu emntwini kwimilenze yakhe kufutshane nomzantsi.
9. Abanonopheli baqinisekisa ukuba babamba kakuhle, baze bolule imilenze yabo yangaphandle baphakamise baze bashenxise umntu.
10. Ukuba umntu mkhulu okanye uyasinda, endaweni yokungqiyama ngenye ingalo, umnonopheli angabeka eso sandla kumzantsi womntu ukumnceda ekuphakamiseni ubunzima.

Kwibhedi ephakamileyo

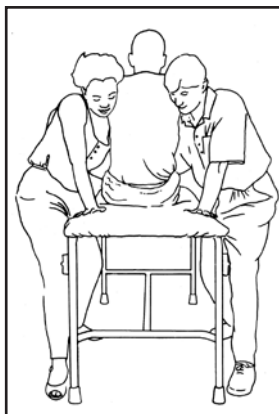

1. Zisa umntu kwindawo yokuhlala kwaye ugobe amadolo akhe.
2. Abanonopheli bema kwelinye icala lebhedi, bejonge emntwini.
3. Imilenze yabanonopheli kufuneka yohlukane ngokobubanzi beligxa, unyawo lwangemva lungqamana nomzimba womntu, aze amadolo agobe kancinane. Iinyawo zabo zangaphambili kufuneka zijikwe zisiwe kwicala lentshukumo.
4. Abanonopheli babeka amagxa abo kufutshane nomzimba womntu, kanye nje ngaphantsi kwekhwapha, beqaphela ukuba abatyhilizeli amagxalaba abo emakhwapheni. Umntu angabeka ingalo yakhe emva komnonopheli.
5. Abanonopheli bazixhasa ngezandla kude lee emntwini.

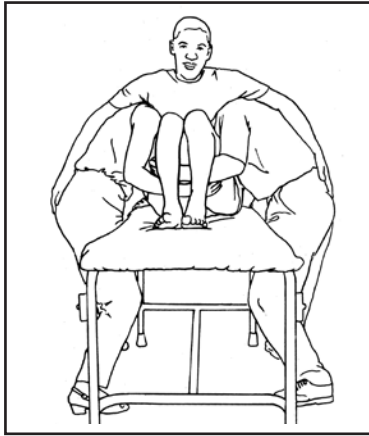

6. Abanonopheli basongela ezinye izandla zabo kumlenze ophezulu womntu kufutshane nomzantsi.
7. Ukuphakamisa umntu, abanonopheli bobabini bacinezelela amagxalaba abo kumzimba womntu, bathi nkqi iingalo zabo emilenzeni baze bayibambe imilenze.
8. Ukuba umntu mkhulu okanye uyasinda, endaweni yokuba angqiyame kwesinye isandla, umnonopheli angabeka eso sandla ngaphantsi komzantsi womntu ukumnceda ekuphakamiseni ubunzima.

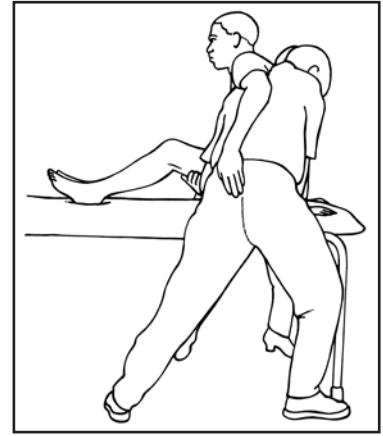

9. Abanonopheli baphakamisa baze bashenxise umntu ngokwelula amadolo abo nokubhekelisa ubunzima babo buye kwimilenze yabo ephambili nakwiingalo ezixhasayo.



Ndingamgqithisela njani umntu ozishenxela kancinane ngokwakhe?

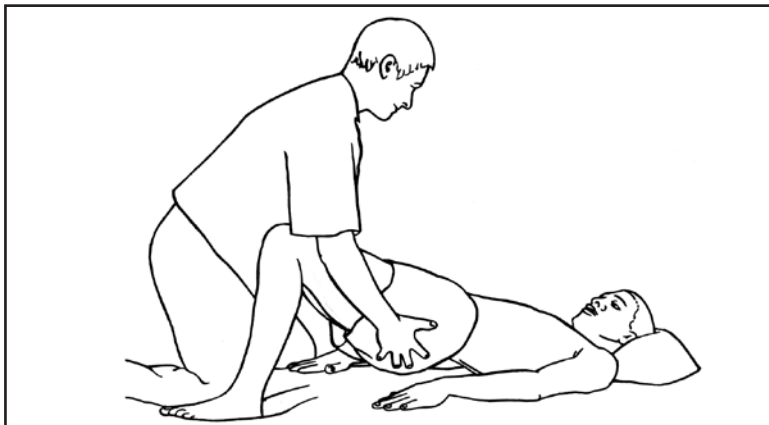

1. Guqa ngedolo elinye ebhedini ecaleni komntu.
2. Nceda umntu agobe amadolo akhe.
3. Inyawo zomntu zihlala bhaxa ebhedini. Beka idolo lakho phambi kweenyawo ukuze iinyawo zingatyibiliki.
4. Nceda ekuphakamiseni iinyonga.
5. Emva koko nceda ekubhekeliseni iinyonga ziye ecaleni.

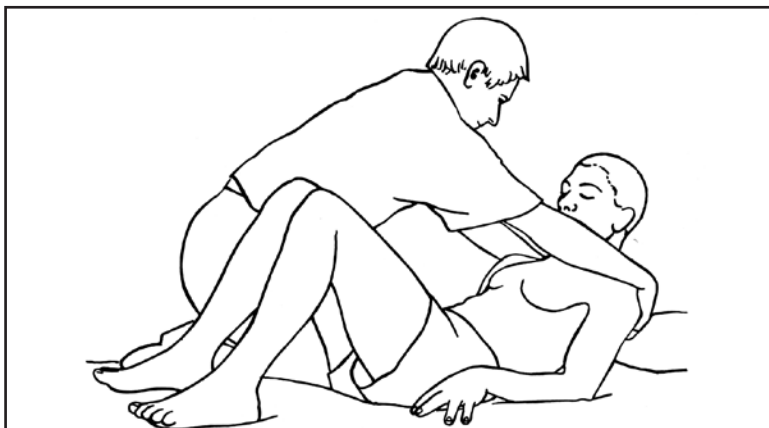

6. Bamba umntu ngamandla emva kwamagxalaba.
7. Cela umntu ukuba aphakamise intloko yakhe.
8. Mncede aphakame kwaye abhekelise intloko namagxalaba ngokubamba amagxalaba.
9. Ungamtsali entanyeni okanye engalweni.
10. Yiya ecaleni ngokuqala uphakamise uze ushenxise intloko, emva koko amagxa uphinde emva koko ushenxise iinyonga.

Ingaba umntu ungamqengqela njani kwicala elibuthathaka nakwicala elomeleleyo

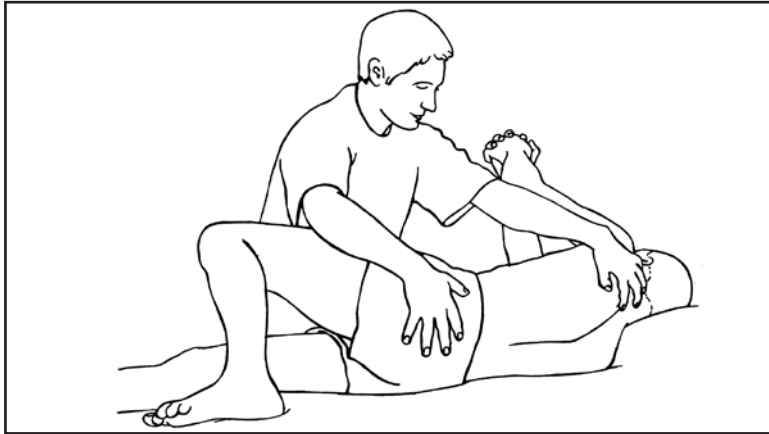

1. Cela umntu adibanise izandla zakhe okanye abambe ingalo ebuthathaka ngaphantsi kwesihlahla ngobhontsi wakhe ekhombe eminweni. Umntu kufuneka ngobunono alule igxalaba elibuthathaka liye phambili.
2. Goba idolo ekufuneka liqengqelekile, uze uqengqe umzimba.
3. Cela umntu aphakamise intloko namagxa.
4. Xhasa umntu kwiinyonga nasemagxeni.

Ingaba ungamnceda njani umntu ekulaleni ngendlela yokuhlala

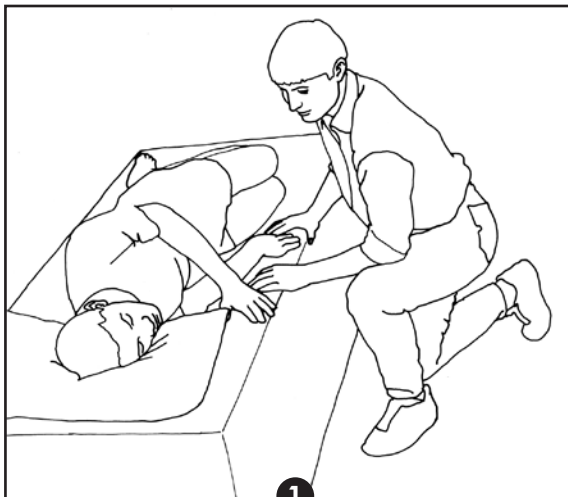

1 Qengqa umntu aye kwicala lakhe elibuthathaka.

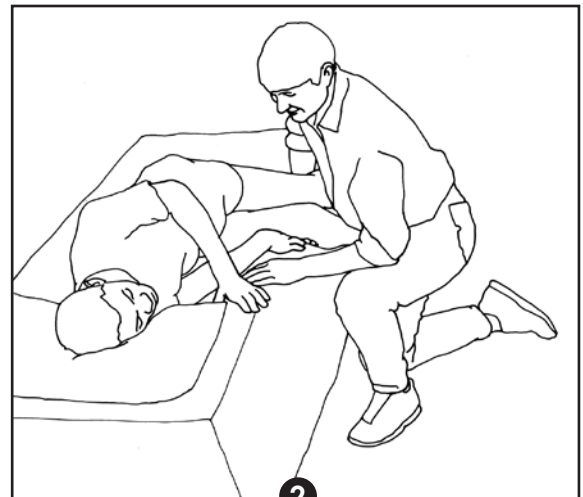

2 Jingisa imilenze yakhe ngaphaya komphetho webhedhi.



3 Ungaxhasa ngesandla esinye ngaphantsi kweembambo esinye sixhase kwelinye icala leligxa, okanye ngokubeka izandla zombini emagxeni.
Ungaphinda ubeke isandla esinye kwigxalaba lomntu esinye isandla kwinyonga yakhe.



4 Cela umntu azinyanzele akhwele ebhedini ngeengalo zombini ukuze aphakamise umzimba. Umntu angaze abambebelele kuwe okanye atsale umqala wakho.



Ndingamkhokela njani umntu ukuba aye ebhedini ngaphandle koncedo?

Indlela yokuya ebhedini

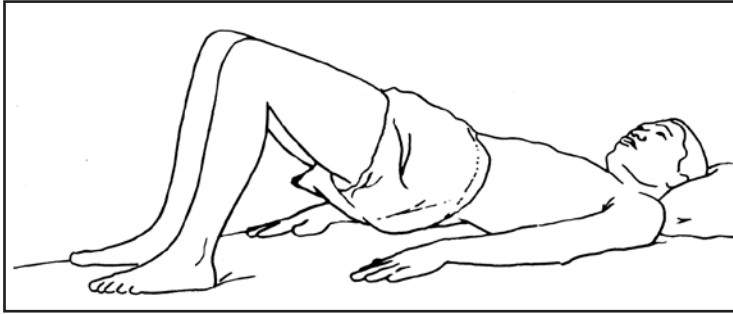

Cela umntu ukuba maka:

1. Gobe amadolo akhe.
2. Gcine iinyawo zakhe zinabile.
3. Phakamise iinyonga zakhe ngokuzityhalela ezinyaweni.
4. Shenxe aye ecaleni okanye atyhalele phezulu.
5. Phakamise intloko yakhe kunye namagxalaba aze ashenxe.

Uziqengqa njani ebhedini

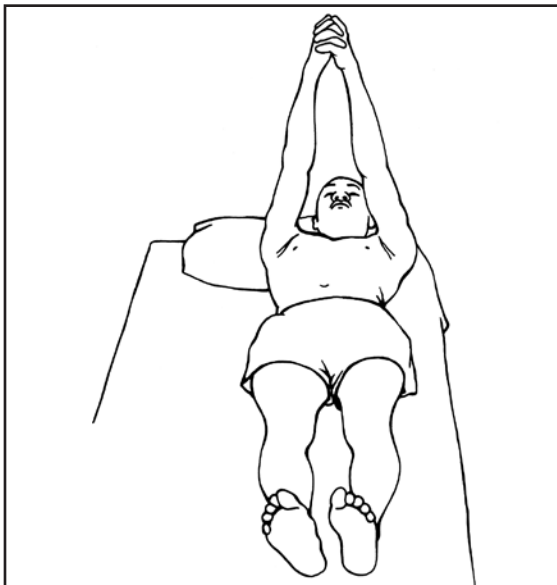

Cela umntu ukuba maka:

1. Shenxele kwicala lebhedi njengokuba kucacisiwe ngentla.
2. Dibanise izandla zakhe kunye okanye abamba ngamandla ingalo ebuthathaka ngaphantsi kwesihlahla ngobhontsi wakhe ekhombe eminweni.

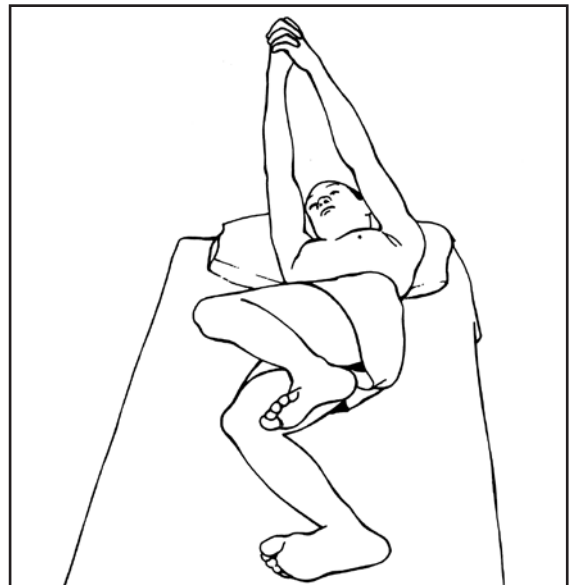

3. Phakamise iingalo zakhe, uze ngobunono utsalele iigxalaba elibuthathaka phambili.
4. Phakamise intloko, amagxalaba kunye neenyawo.

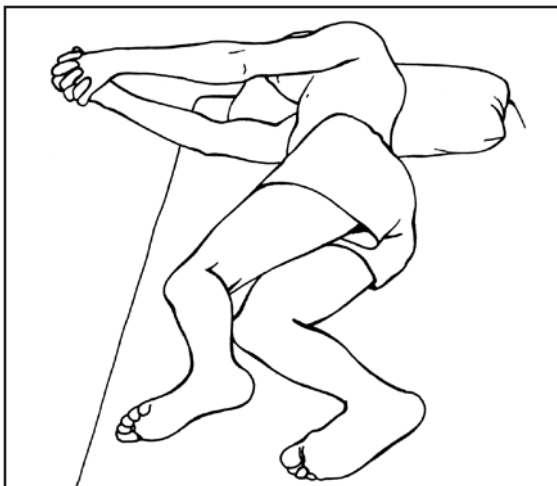

5. Ziqengqe.

Indlela yokuhlala nkqo

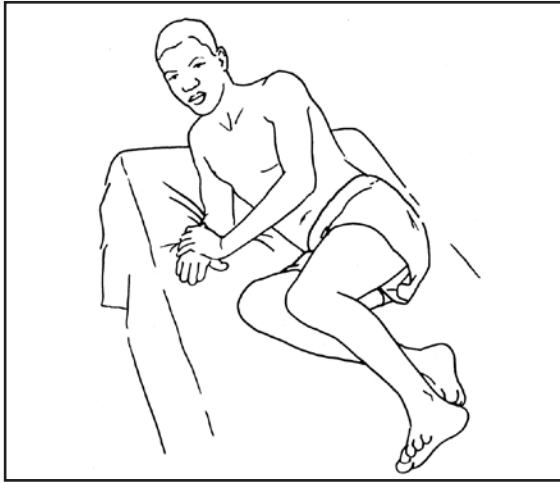

Cela umntu ukuba maka:

1. Qengqelekele kwicala lakhe elibuthathaka.
2. Gwegwe unyawo lwakhe olomeleleyo emva kweli libuthathaka aze ajingise imilenze ngaphaya komphetho webhedhi.

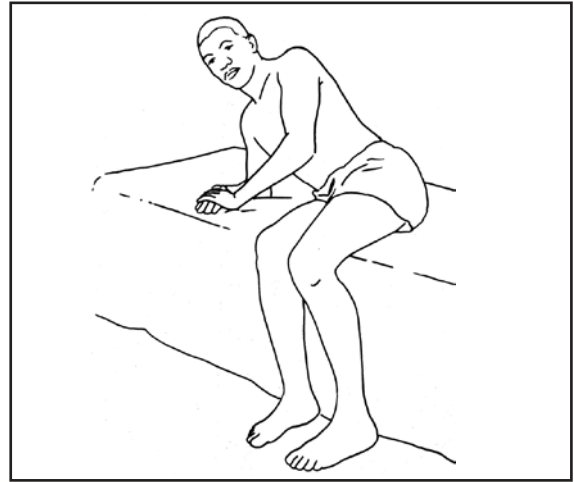

3. Nyuke aye kwinqiniba ngokutyhalela ezantsi ngeengalo zombini.



4. Qhubeke nokutyhalela kwizandla zombini aze olule iinqiniba.

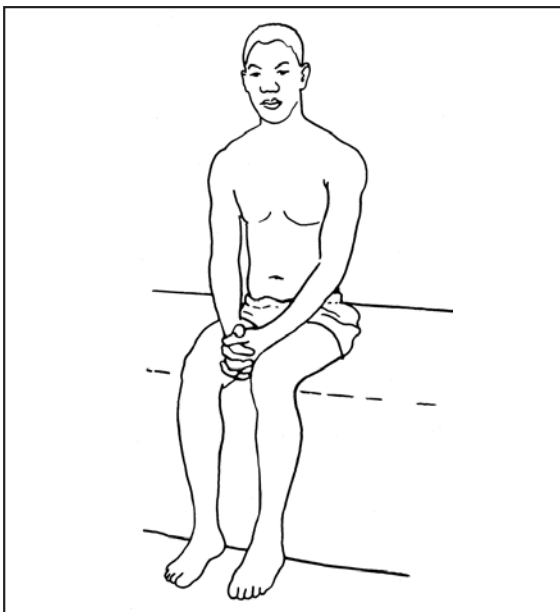

5. Zolule okokoko uze uqinisekise ukuba uhlalela ngemva kude ngokwaneleyo ukuze ibhedhi ixhase amathanga ngokupheleleyo.

8. Ukugqithisela (ukusuka ebhedini ukuya esitulweni)

Imithetho-siseko ngokubanzi:

- Beka isitulo esinamavili okanye isitulo kufutshane nebhedini.
- Tshixa iziqhoboshi zesitulo esinamavili.
- Umnonopheli omdana okanye owomeleleyo kufuneka abe ngasemqolo.
- Abanonopheli kufuneka basebenzisane.
- Gqibani kwangaphambili ukuba ngubanii oza kunika imiyalelo, kwanokuba iza kuthini le miyalelo.
- Bonisa xa uza kuqalisa ukuphakamisa, nokuba kungokuphakamisa 'kwisithathu' xa ubala usiya kwisithathu okanye uwabize amanani. 'Nye, mbini, phakamisa.'



Ingaba abantu ababini bangamgqithisela njani umntu obuthathaka kakhulu ukusuka esitulweni ukuya ebhedini esezantsi?



Indawo yomntu:

1. Umntu usonga izandla zakhe.



Indawo yomnonopheli ongasemva:

2. Umnonopheli ongasemva uthubelezisa iingalo zakhe phakathi kwen-galo eziphezulu kunye neembambo zomntu.
3. Umnonopheli ubamba zombini iingalo ezingaphambili zomntu azisondeze kwiingqiniba.



Indawo yomnonopheli ongapambili:

4. Omnye umnonopheli uyaguqa okanye achophe phambi kwebhedini omnye umlenze ungapambili komnye.
5. Lo mnonopheli ubeka iingalo zakhe ngaphantsi kwamadolo omntu naphezulu emathangeni, kufutshane kakhulu kumzantsi.
6. Imilenze yomntu ingaphumla kumathanga omnonopheli okanye ingaphumla kwinxalenye yebhedini.



Amanyathelo omnonopheli ongaphambili:

7. Umnonopheli ongapambili, uphakamisa imilenze yomntu, ayibambe isondele kakhulu emzimbeni wakhe aze azise ubunzima phambili komnye umlenze ukuze ase umntu ebhedini

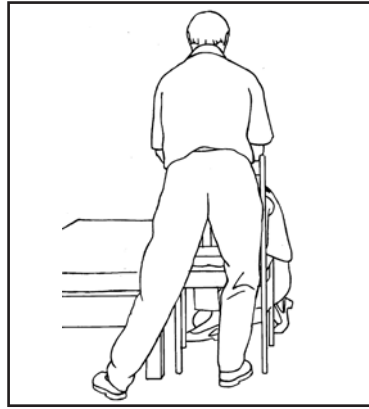

Amanyathelo omnonopheli ongasemva:

8. Umnonopheli ongasemva uyama imilenze yakhe ivuliwe kwaye igotywe kancinane, ze olule imilenze yakhe ukwenyusa umntu. Umnonopheli angagoba idolo elikufutshane kakhulu ebhedini ukuze aguqe ebhedini.



Amanyathelo omnonopheli ongasemva:

9. Umnonopheli ongemva ngoku usa ubunzima bakhe kumlenze osondele ebhedini aze abhekisele umntu ngaphaya.

Landela la manyathelo angasentla ngohlobo olubuya umva ukubuyisela umntu esitulweni.



Ingaba abantu ababini bangamshenxisa njani umntu obuthathaka kakhulu osuka esitulweni ukuya ebhedini ephakamileyo?



1. Abanonopheli kufuneka bame ngendlela ecacisiweyo ngasentla. Umnonopheli ongapambili angaguqa okanye achope phantsi, omnye umlenze ube phambi komnye.
2. Imilenze yomntu kufuneka iphumle kumathanga omnonopheli.



3. Umnonopheli osemqolo kufuneka aphakamise njengokuba kucacisiwe ngentla. Ukuba umnonopheli womelele, angama kwiqonga elomeleleyo.
4. Umnonopheli ongapambili uphakamisa amazantsi omntu kunye nemilenze ngokuphakama.

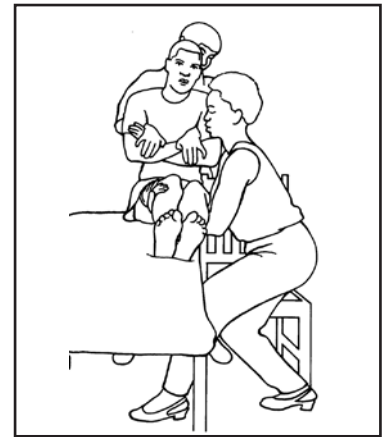

5. Umnonopheli ongemva udlulisela ubunzima bakhe kumlenze osondele ebhedini aze ashenxisele umntu ngaphaya.
6. Umnonopheli ophambili uya phambili ngomlenze wakhe wangemva aze ase imilenze yomntu namazantsi akhe ebhedini.

Landela la manyathelo ngohlobo olubuya umva ukubuyisela umntu esitulweni.



Ingaba umntu omnye angamnceda njani umntu ashenxe phakathi kwebhedi nesitulo?

Imigaqo jikelele ithi:

- Nceda umntu ashenxise amazantsi akhe aye phezulu esihlalweni okanye ebhedini.
- Yehlula iinyawo zakhe kancinane nasemva kwamadolo.
- Cela umntu agcine umqolo wakhe uthe nkqo kwaye agobe kwiinyonga aze angqiyamise intloko yakhe namagxa phambili ngapha kwamadolo.
- Lumkela ukusondela kakhulu emntwini. Buyisela owakho umzimba ngemva xa bengqiyamela ngaphambili.
- Cela umntu ukuba makame nkqo ngoko nangoko xa impundu zakhe ziphakama.



Ingaba umntu ungamshenxisa njani ngokuma xa edinga ukuxhaswa ngakwidolo elibuthathaka?

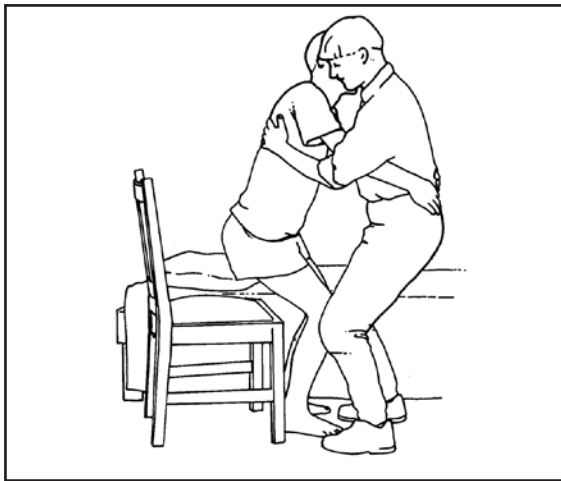

1. Beka isitulo ecaleni kwebhedi.
2. Xhasa idolo elibuthathaka ngedolo macala ngamadolo akho. Sukulivalela idolo ngaphambili.

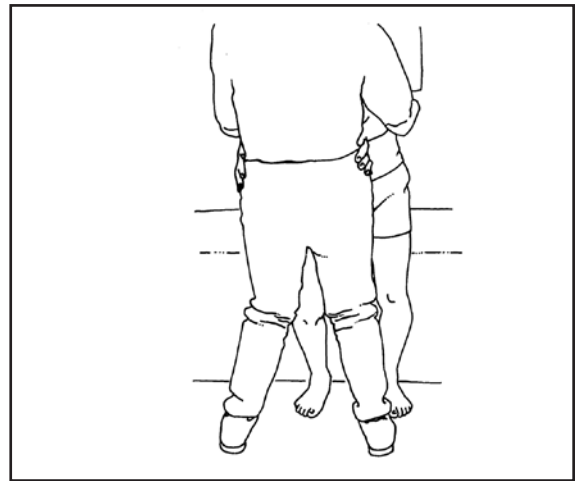

3. Zisa umntu ngaphambili naphezulu ngokushenxisa amagxa aye ngaphambili naphezulu.
4. Mjijele ngasebhedini uze umhlalise phantsi ngokucotha umntu

Indlela yokushenxisa umntu obuthathakana, onzinyana okanye omdana ngebhodi etyibilikayo.

Sebenzisa iceba eliflethi lokhuni ukuze umntu atyibiklike kulo. Qiniseka ukuba umphezulu kunye namacala akanazingceba. Sebenzisa ibhodi kuphela xa umntu sele enxityisiwe.

Imilinganiselo kunye neenkukacha ezimalunga neenkqubo zokwakha ibhodi yokudlulisela.

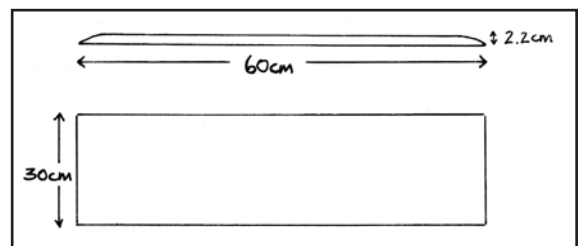
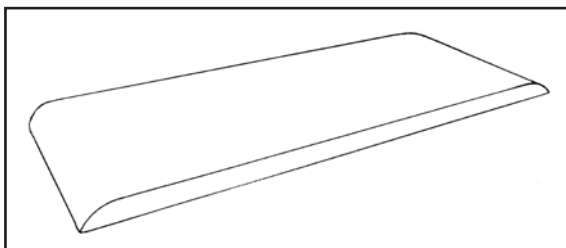



Ndingamkhokela njani umntu oneenyawo ezibuthathaka kunye neengalo ezomeleleyo ukuba asuke esitulweni aye ebhedini ngaphandle koncedo?



1. Misa ngendlela isitulo esinamavili ngakwibhedini ngecala elincinane. Tshixa iziqhoboshi. Susa indawo yokuphumza izandla ekufutshane nebhedini.
2. Zimise ngendlela leyo ubuza kwenza ngayo xa ushenxisa umntu ngokuma.
3. Ngqiyamisa umntu kude nebhedini uze ufake ibhodi ngaphantsi kwempundu yakhe ekufutshane kakhulu nebhedini.
4. Beka ibhodi ukwenza ibhulorho ephakathi kwebhedini nesitulo esinamavili.
5. Cela umntu ukuba agcine umqolo wakhe uthe nkqo aze angqiyamise intloko yakhe namagxa ngaphambili ngapha kwamadolo.
6. Bhekelisa umzantsi womntu ngaphaya xa ubunzima bakhe bususwa ebhodini.
7. Ukuba umntu ubuthathaka, shenxisa kuphela umganyana omncinane. Phinda ade ahlale ebhedini.
8. Buyisela umva la manyathelo ukubuyisela umntu kwisitulo esinamavili.



Indlela yokunceda umntu oneengalo ezomeleleyo kunye nemilenze ebuthathaka ukuba ashenxe

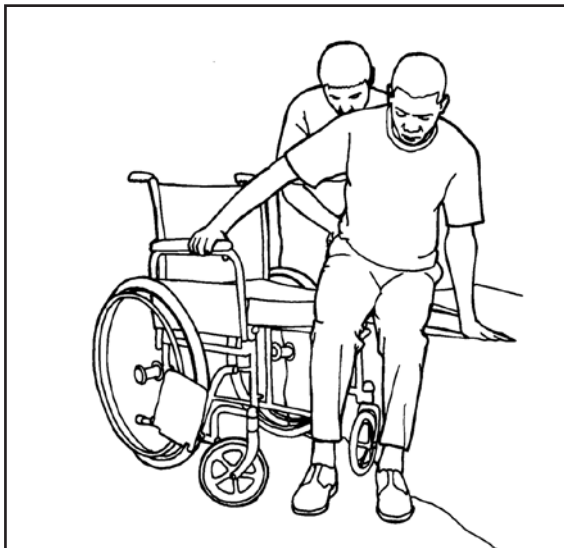

1. Faka ibhodi njengoko kucaciswe ngentla.
2. Shenxa uye emva komntu uze uguqe ebhedini ngomlenze wakho osondele kakhulu ebhedini. Beka ngendlela omnye umlenze phakathi kwebhedini nesitulo esinamavili.
3. Beka izandla zakho kumacala onke eenyonga zomntu lowo.



4. Cela umntu atyhalele ezantsi izandla zakhe aze aphakame ashenxise iimpundu ziye macala.
5. Ncedisa ekuphakamiseni nasekushenxiseni iimpundu.
6. Phinda phinda ade umntu abe sebhedini okanye esitulweni.



Ndingamkhokela njani umntu oneenyawo ezibuthathaka kunye neengalo ezomeleleyo ukuba asuke esitulweni aye ebhedini ngaphandle koncedo?

Indlela yokudlulisela ngebhodi



1. Faka ibhodi phantsi kweempundu.
2. Ngqiyamela phambili uze uthathe obunye ubunzima ngeenyawo.
3. Tyhalela ezantsi ngeengalo.
4. Shenxela ngaphaya ngokubhekelela ecaleni kancinane.
5. Sukuma oko.



Ndingamnceda njani umntu ekumeni ngoncedo oluncinane?



1. Nceda umntu ashenxe ngeempundu zakhe aye emphethweni webhedini.
2. Imilenze yomntu kufuneka ihlukane kancinane, ingqamane omnye nomnye kwaye ibe semva nje kancinane emadolweni.



3. Xhasa ingalo ebuthathaka ngenyonga yakho. Ukuba ingalo iqinile okanye ibuhlungu, yiyeke ijinga phakathi kwamadolo omntu.



4. Bamba umntu ngegxabala emzimbeni, hayi engalweni epehuzulu. Xhasa ingalo yomntu ngeengalo yakho ephambili.

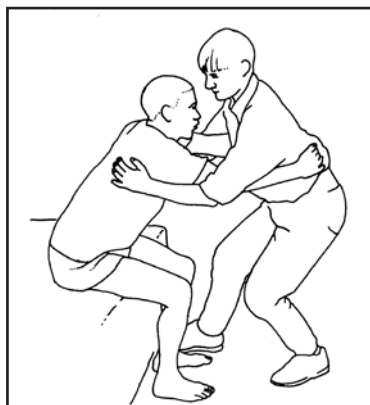

5. Khokela amagxalaba omntu aye phambili ngokususa ubunzima bakho buye kunyawo lwakho olusemva.

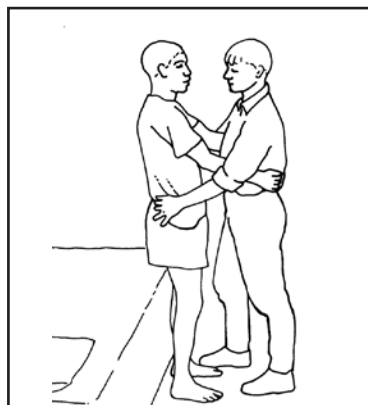

6. Ncedisa umntu ukuba ame. Mvumele umntu azenzele oko anako ngokwakhe.



Ndingamkhokela njani umntu ekumeni ngaphandle koncedo?

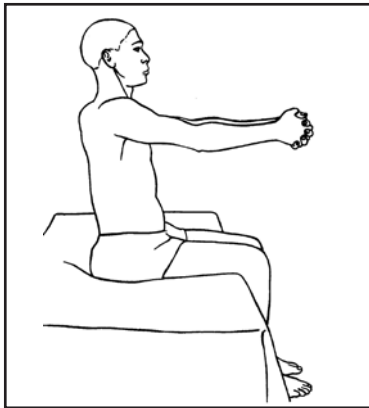

1. Ahlale nkqo.
2. Bamba izandla ngokuqinileyo okanye ubambe ingalo ebuthathaka ngezantsi nje kwesihlahla ubhontsi ekhombwe eminweni.

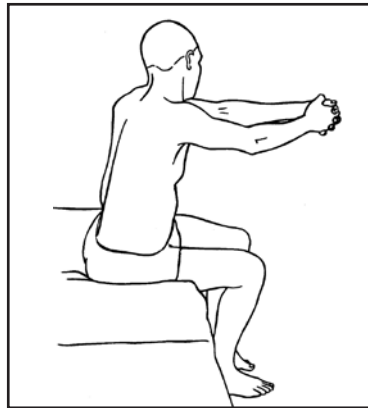

3. Shenxa uye phambili ngeempundu.

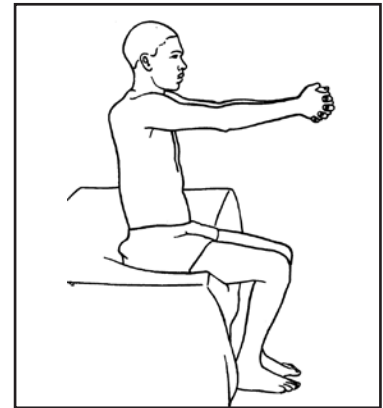

4. Yeka kumphetho webhedidi. Beka imilenze yahlu-kane kancinane, ingqamane omnye nomnye kancinane nje ngasemva kwamadolo.

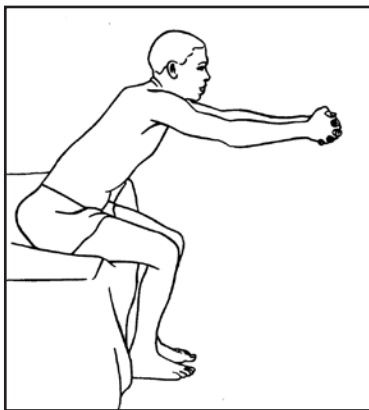

5. Ngqiyamela phambili ukusukela ezinyongeni ukuya emagxeni ade abe amagxa angaphambi kwamadolo neenyawo. Fikelela phambili ngezandla ukunceda ekuziseni ubunzima phambili.

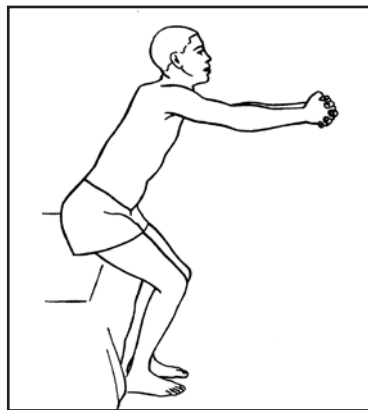

6. Qalisa ngokuphakamisa umzantsi nokolula amadolo athi tye. Sukudulela amadolo ebhedini okanye esitulweni.

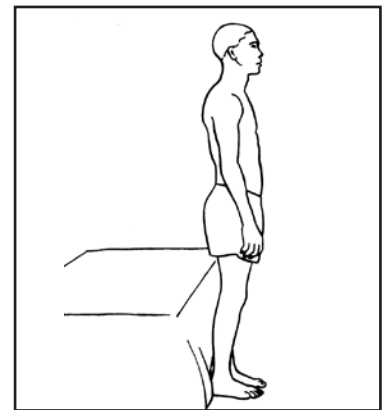

7. Yima nkqo.

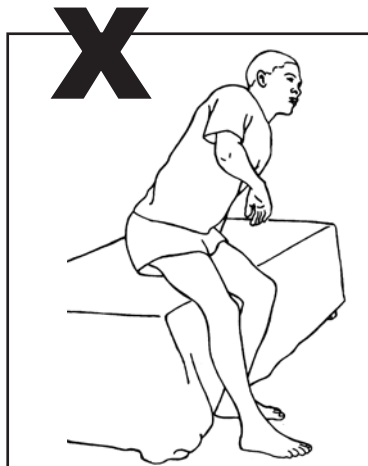

Ungaze uphakame ngokudulela phezulu isandla esomeleleyo kuphela. Ukuba umntu usebenzisa kuphela icala elomeleleyo lomzimba wakhe, liza kwenza ubuthathaka obungaphaya kunye nokuqina kwicala elibuthathaka. Kungcono wolule izandla zombini ziye phambili uze uziphumze kumva wesitulo, eludongeni okanye kwelinye ilungu lefenitshala ukunceda.

9. Ukuzikhathalela



**Menze umntu
azenzele okuninzi
ngokwakhe.**

Ulawulo lwesinyi nokuzithuma (iimfuno zangasese)

Zininzi izizathu ezingenza ukuba abantu bangakwazi ukulawula isinyi sabo okanye ukuzithuma. Nabani ofumana le nto kufuneka abonane nogqirha, onganyanga ezinye iingxaki aze anike namayeza okuphucula ulawulo.



Ungamnceda njani umntu ekulawuleni isinyi sakhe

Cacisa izikhokhelo ezibanzi emntwini lowo, ngale ndlela ilandelayo:

- "Sela iiglaszi zamanzi ezintandathu ukuya kwisibhozo ngemini. Gcwalisa ibhotile ezilitha ezimbini yonke imihla, uze uyifake kwifriji okanye uyibeke ecaleni kwebhedi okanye kwesitulo. Sukusela nganeno kuba usoyika ukuba nengozi.
- Sukusela kwanto ubuncinane kwiyure enye phambi kokuba ulale ukuba uye uzichamele ebusuku.
- Yiya ngasese kanye ngaphambi kokuba ulale kwaye ibe yinto yokuqala oyenzayo kusasa.
- Gquma umatraszi ngeshiti leplastikhi, uze ugqume iplastiki ngetawuli okanye ngephepha-ndaba ngaphambi kokuba uwugqume ngeshiti. Sukulala okanye uhlale kanye kwisigqumatheli seplastikhi.
- Yiya ngasese qho emva kweyure ezimbini. Kancinane nyusa eli xesha ukuya kwiyure ezine ngexesha.
- Umbala womchamo kufuneka ube mnyamana ngebala kancinane kunamanzi. Ukuba unebala elimdaka kakhulu, uyanuka, okanye unegazi, yiya eklinikhi ukuze uxilongelwe usulelo olunokubakho. Umchamo onebala elimdaka uqhele ukuthetha ukuba akuseli amanzi awoneleyo."

Ukuba umntu unxiba ikhathetha (umbhobho nesingxoba):

- Hlamba izandla ngalo lonke ixesha phambi nasemva kokusebenza ngekhathetha.
- Khupha okusesingxobeni ngalo lonke ixesha.
- Sukubopha umlenze wesingxobo uqine kakhulu.
- Ukuba akukho mchamo esingxobeni emva kweyure ezine, kunokwenzeka ukuba umbhobho uvalekile. Yisa umntu eklinikhi.



Ndingamnceda njani umntu ongakwazi ukulawula ukuzithuma

- Kufuneka ukuba ugqirha afake umntu kwinkqubo yokuzithuma ukuba umntu akeva nto ebonisa ukuba kufuneka aye ngasese.
- Misela inkqubo elandelwayo yokuzithuma, efana nokuya ngasese qho kusasa emva kwesidlo sakusasa.
- Menze umntu ahlale ethoyilethi okanye etshembeni.
- Ukunqanda ukuqunjelwa:
 - Kufuneka ukuba umntu asele iiglaszi zamanzi ezintandathu ukuya kwezisibhozo ngemini.
 - Kufuneka ukuba umntu achithe ixesha lakhe kangangoko anako engekho sebhedini emini.
 - Kufuneke ukuba umntu ahlale exakekile kangangoko anako.
 - Kufuneke atye ukutya okuqulathe izinto ezirhabaxa (ifayibha), umzekelo iziqhamo ezingaxotyulwanga, imifuno, iziqhamo ezomisiweyo, amazimba, isonka esimdaka kunye nerayisi emdaka ngebala.
- Yisa umntu lowo eklinikhi ukuba unorhudo oluthatha ngaphezu kweentsuku ezintathu.

? Ingasetyenziswa njani itshemba?



Itshemba yeyokuchamela kuphela. Kufuneke umntu ahlale nkqo ukwenzela intshukumo yamathumbu.

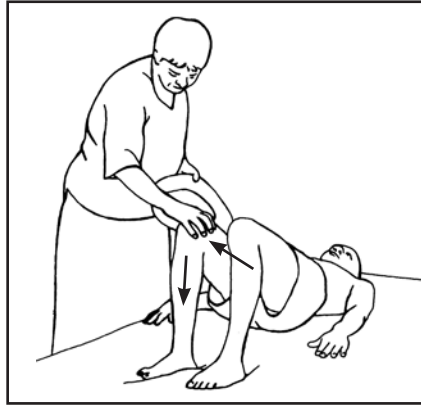

1. Xhasa idolo elibuthathaka ngesandla sakho ngexesha umntu esenyusa iinyonga zakhe.
2. Tsalela idolo phambili nasezantsi ngaphaya konyawo ukuze unyawo lungatyibiliki okanye luphumele ngaphandle.

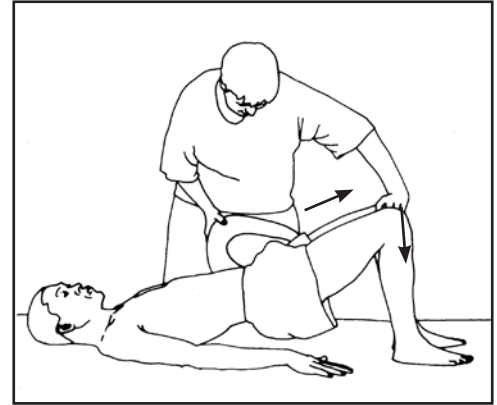

3. Faka itshemba.

? Ingaba umnonopheli omnye angamnceda njani umntu aye ngasese?



1. Ukuba akukwazeki ukubeka isitulo esinamavili kwiqondo elingama-90 ukuya ethoyilethi, sibeke njenge-engile kangangoko unako. Faka iziqhoboshi.

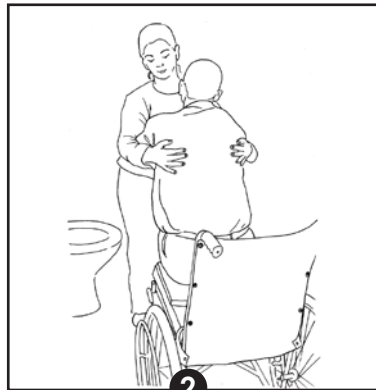

2. Nceda umntu ashenxele phambili esitulweni aze aphinde ame.



3. Xhasa idolo elibuthathaka ngedolo lakho. Thubelezisa izandla zakho kwiinyonga zomntu ukumnceda ekuzinzeni.

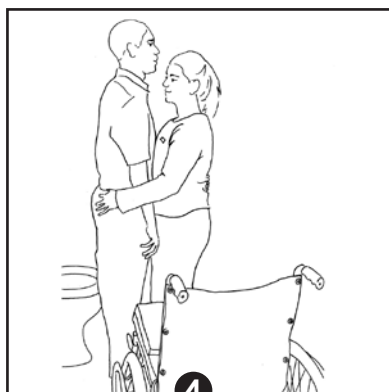

4. Guquka ade umntu ame phambi kwethoyilethi. Mncede akhulule impahla yakhe.



5. Kancinane khokelela umntu ekuhlaleni phantsi.



Ingaba umntu uya njani ngasese ngaphandle koncedo?



1. Faka iziqhoboshi zesitulo esinamavili kwaye ushenxele phambili esitulweni.
2. Bamba izandla kunye ngokuqinileyo.
3. Yima.



4. Guquka.
5. Beka izandla ezibanjwe kunye ngokuqinileyo esitulweni ukwenzela ukuxhasa, ukuba kuyadingeka.

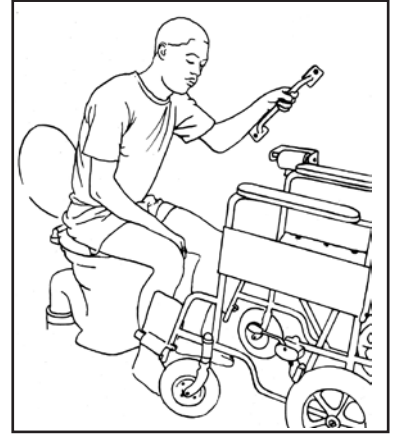

6. Hlala phantsi kwithoyilethi.
7. Ukuba ukuma ngaphandle kokuxhaswa ngezandla akunakwenzeka, sebenzisa intsimbi yokuxhasa uze wenze ukuba isandla esibuthathaka sijinge phakathi kwemilenze.



Izixhobo ezinganceda ekuyeni endlwini yangasese



Isihlalo esiphezulu sethoyilethi: Sisebenza kakuhle kubantu abade, abadala abaneengxaki zeenyonga nezamadolo, okanye xa ithoyilethi isezantsi kakhulu.

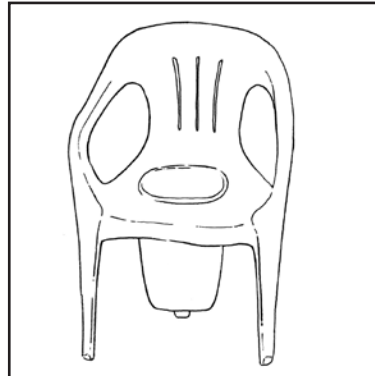

Isitulo seplastikhi esinomngxunya esihlalweni kunye nepheyile ngaphantsi.

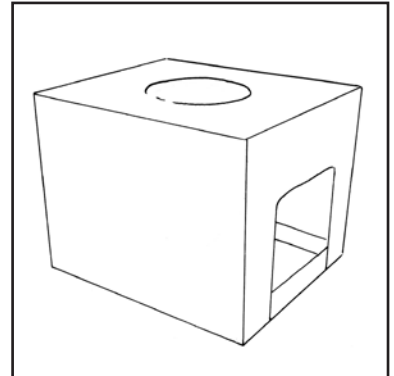

Yenza isihlalo setshemba ngamaplanga.

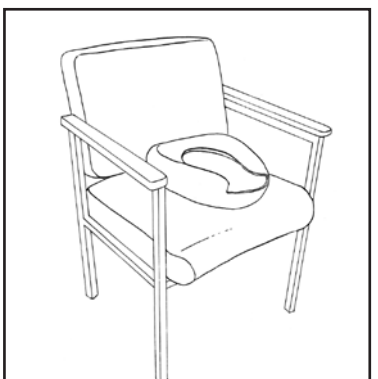

Sebenzisa itshemba kwisitulo esinesihlalo esomeleleyo.



Sebenzisa itshemba kwisitulo esinamavili.

Ukuhlamba

Ndingamhlamba njani umntu esebhedini?

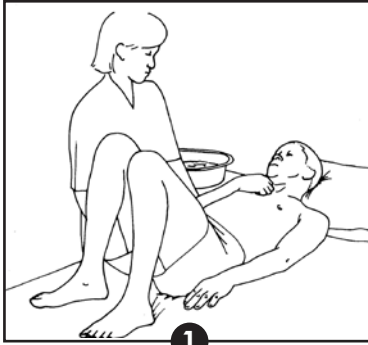

1 Yima kweli cala libuthathaka.

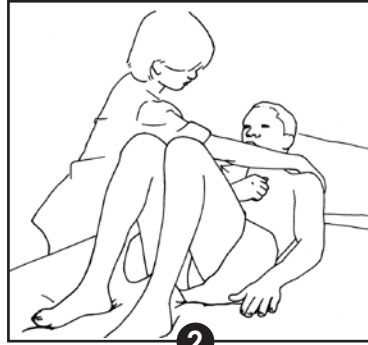

2 Shenxisela umntu kude kwicala lebhedi ngokuphakamisa intloko yakhe kunye namagxa akhe, uze umse embindini webhedi.

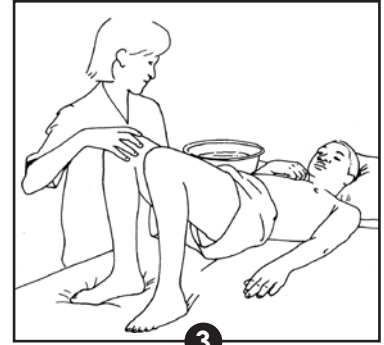

3 Cela umntu ashenixise iinyonga zakhe ngokuphakamisa umzantsi nokushenxela embindini webhedi.



4 Yenza igxalaba likhululeke ngaphambi kokuba uphakamise ingalo. Gwegwa izandla zakho kumacala onke egxalaba uze utsalele igxalaba ngobunono ngaphandle nangaphambili. Phinda oku amaxesha ambalwa lide igxalaba lizishukumele ngokukhululekileyo.



5 Bamba ingalo kanye nje phezu kwengqiniba uze uyijike ngononophelo iye ngaphandle. Yeka ukuba umntu uva iintlungu. Ungabambi ingalo okanye ingalo engezantsi kuba oku kungenza iintlungu okanye umonakalo engqinibeni.



6 Yolula ingqiniba.

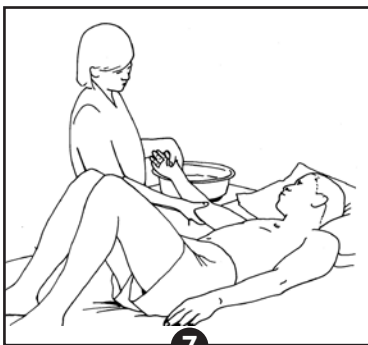

7 Gcina ingalo yakho ijikele ngaphandle. Ngoku yisa ingalo phezu okanye phambili. Yeka ukuba umntu uva iintlungu.

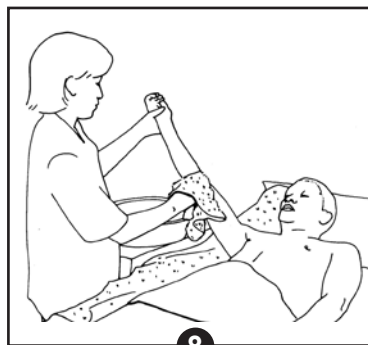

8 Hlamba womise ingalo nekhwapha.

Ukuhlamba umqolo

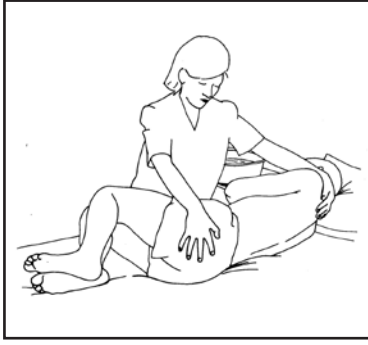

1. Yenza ingalo ebuthathaka ikhululeke ngendlela ekucaciswe ngayo ngasentla. Gcina igxalaba lijonge phambili.
2. Beka ingalo ecaleni ngaphambi kokuba uqengqele umntu ngaphaya.



3. Qengqa umntu aye ecaleni lakhe elibuthathaka.
4. Hlamba umqolo.
5. Sebenzisa itawuli ngaphantsi komzimba.
6. Xa umntu ehleli ngale ndlela, namashiti angatshintshwa.

Ukuhlamba umphantsi

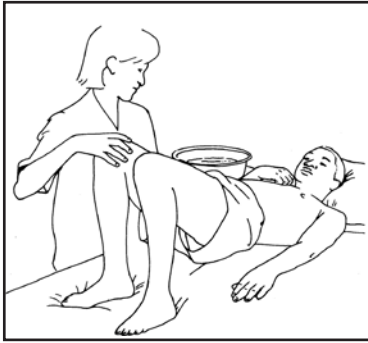

1. Xhasa idolo elibuthathaka ngexesha umntu ephakamisa umzantsi wakhe.
2. Hlamba ngaphantsi.



Angahlamba njani umntu ngaphandle koncedo?

- Hlala kumphetho webhedi.
- Kufuneka ukuba iinyawo ziphumle phantsi okanye kwibhloko yokhuni, okanye kwimfumba yamaphepha-ndaba, okanye kwiikhadibhodi ezidityanisiwe.
- Beka itafile encinane enesitya sokuhlambela, ilaphu, isepha kunye netawuli ngaphambili.
- Xa uhlamba umzimba wangasentla, xhasa isandla esibuthathaka kunye nengqiniba etafileni ukuze zingawi ngaphaya kunye nokunqanda umonzakalo engalweni nasandleni. Oku kuza kunceda ekufikeleleni ekhwapheni nasekuhlambeni ingalo.

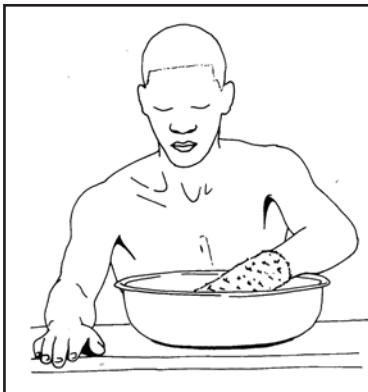

Manzisa ilaphu.

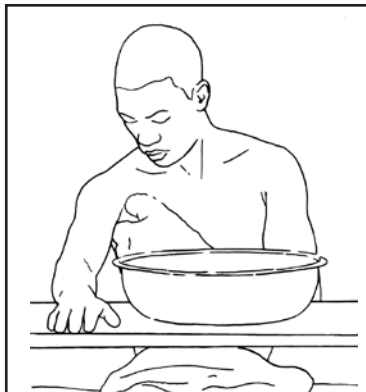

Hlamba ngaphantsi kwen-galo ebuthathaka.

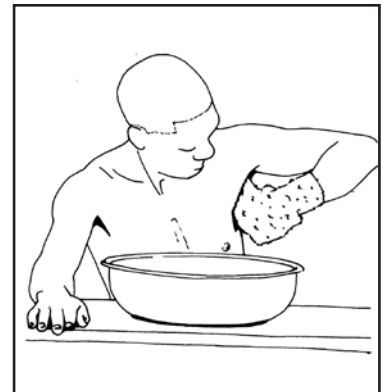

Hlamba ngaphantsi kwen-galo eyomeleleyo.

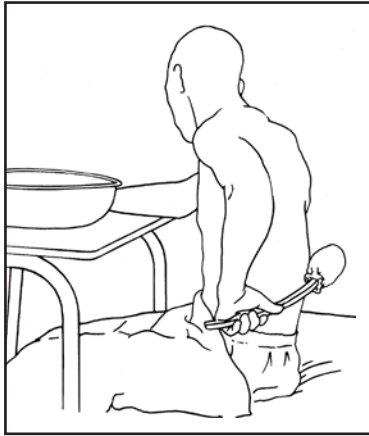

Hlamba umqolo ngebhrashi yomqolo.

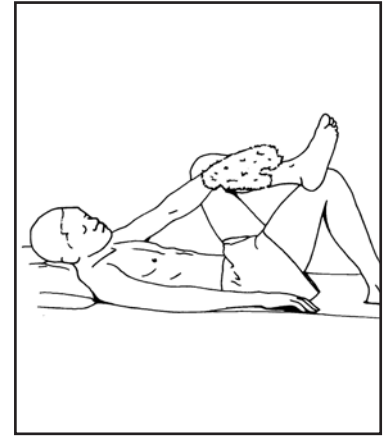

Ukuba akukho kuzinza, lala ngomqolo uze uphithanise iqatha elinye ngaphaya kwelinye idolu ukuhlamba amalungu angaphantsi.

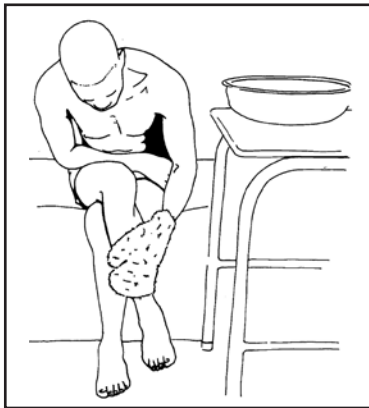

Hlamba amalungu angaphantsi uhleli ukuba akukwazi kuzinza.

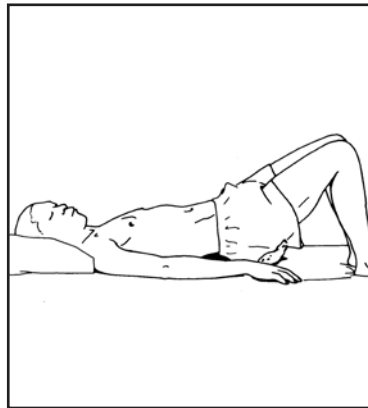

Lala ngesisu ukuhlamba umzantsi.



Sebenzisa imethi yerabha engatyibilikisiyo phakathi ebhafini ukunqanda ukutyibilika.



Ndingamsa njani umntu ebhafini?

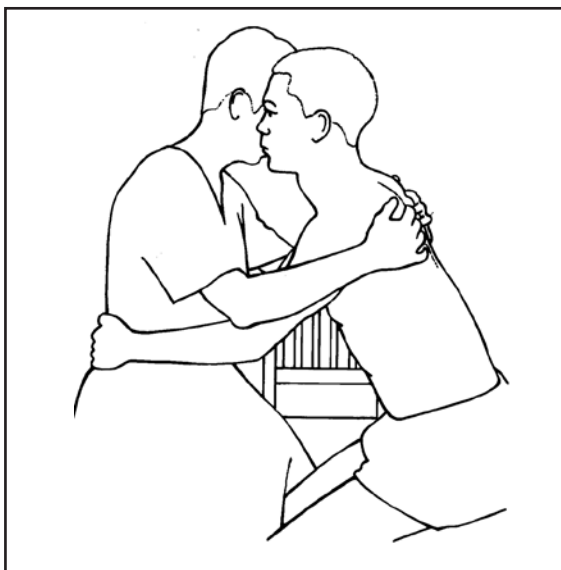

1. Mse ukusuka esitulweni ukuya kwicala lebhafu okanye kwibhodi yebhafu.

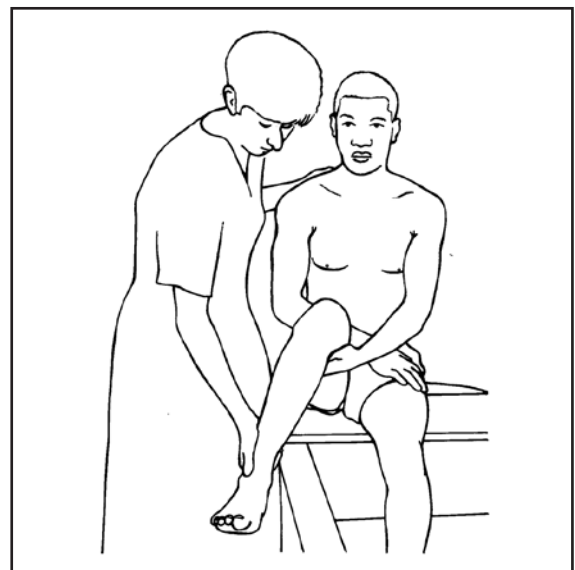

2. Menze umntu ahlale kwibhodi yebhafu.
3. Phakamisa iinyawo zakhe uzifake ebhafini.

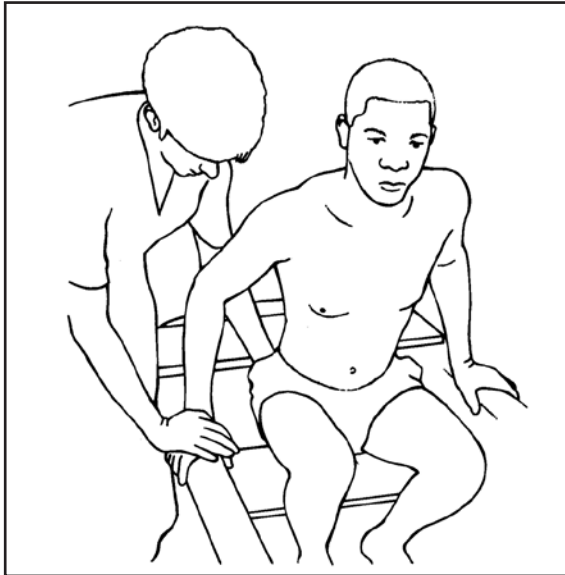

4. Yisa umntu ezantsi phezu kwesihlalo sebhafu. Kufuneka abambelele ngokuqinileyo kwicala lebhafu okanye entsimbini yokubambelela ngesandla esomeleleyo. Ingalo ebuthathaka inokuphumla emathangeni.



5. Xhasa ingalo ebuthathaka kumphetho webhafu okanye kwintsimbi yokubambelela yebhafu ukuba inamandla enawo.
6. Ukuba umntu ubuthathaka kakhulu ukuba angangena ebhafini, angancedwa ekuhlambeni okanye bazihlambe ngokwabo ngexesha behleli ebhodini yokuhlambela. Ishawa yesandla okanye ebude bulungiselelwayo eyenzelwe edongeni ingasetyenziswa.
7. Ukuba umntu unako ukwehla kancinane, sebenzisa isitulo sebhafu. Isitulo sebhafu singena embindini phakathi komphezulu nomzantsi webhafu. Jonga imizekelo emibini yezitulo zebhafu ngezantsi



Izixhobo ezinokunceda ukuba umntu akakwazi kuhlala phantsi ebhafini

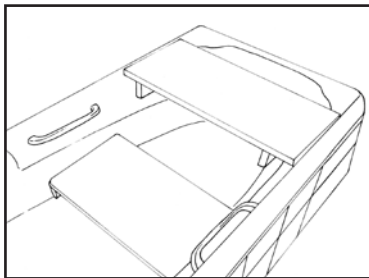

Ibhodi yokuhlambela ekumphezulu webhafu, nesitulo sokuhlambela esiphakathi ebhafini

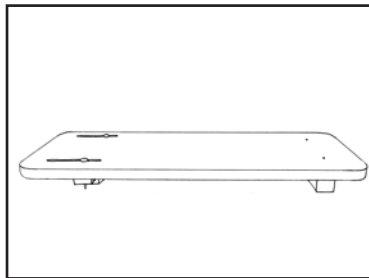

Ibhodi yokuhlambela

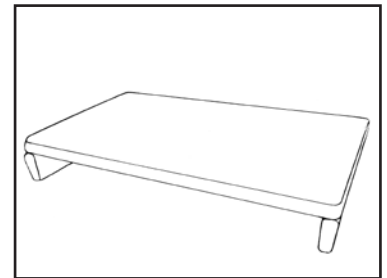

isitulo sokuhlambela

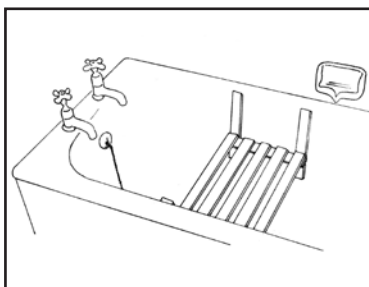

Isitulo sokuhlambela esinemicu.

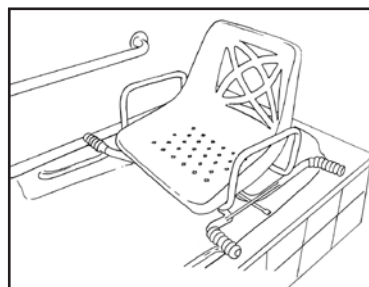

Isitulo sokuhlambela esikwaziyo ukujika

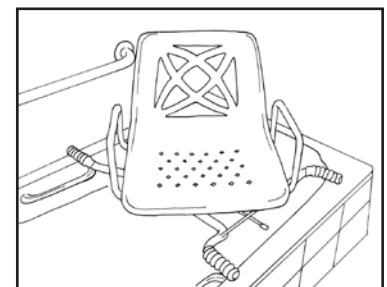

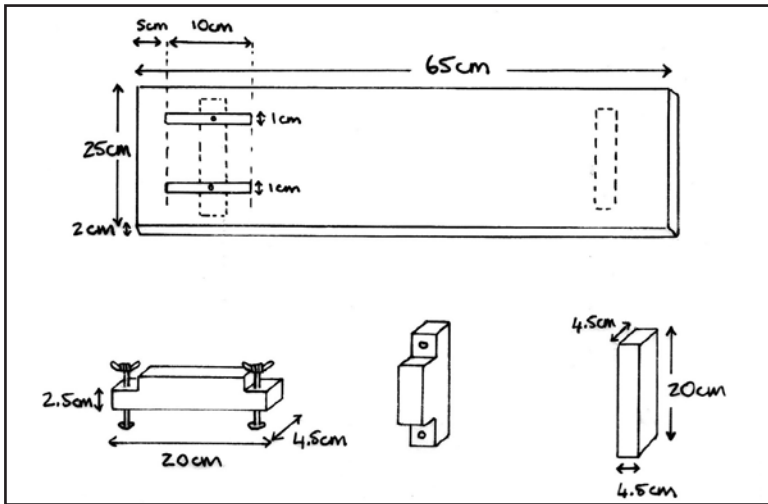

Imilinganiselo kunye neenkukacha zokwakha ibhodi yokuhlambela.

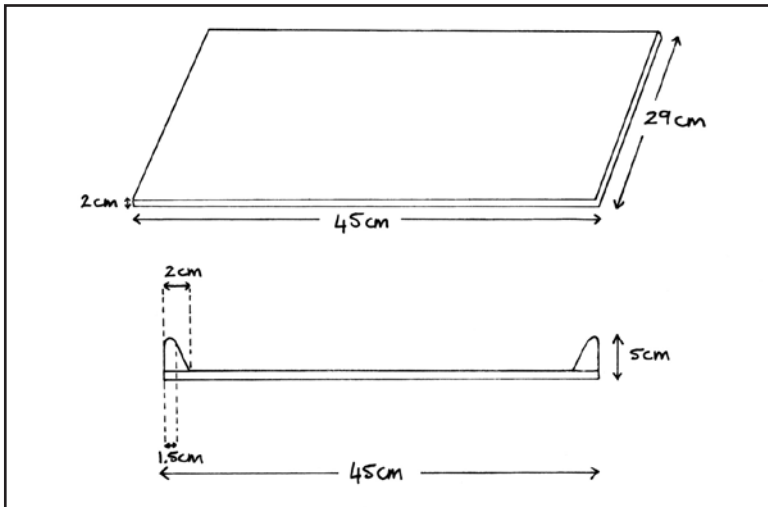

Imilinganiselo kunye neenkukacha ezilandelelanayo zokwakha isitulo sokuhlambela.

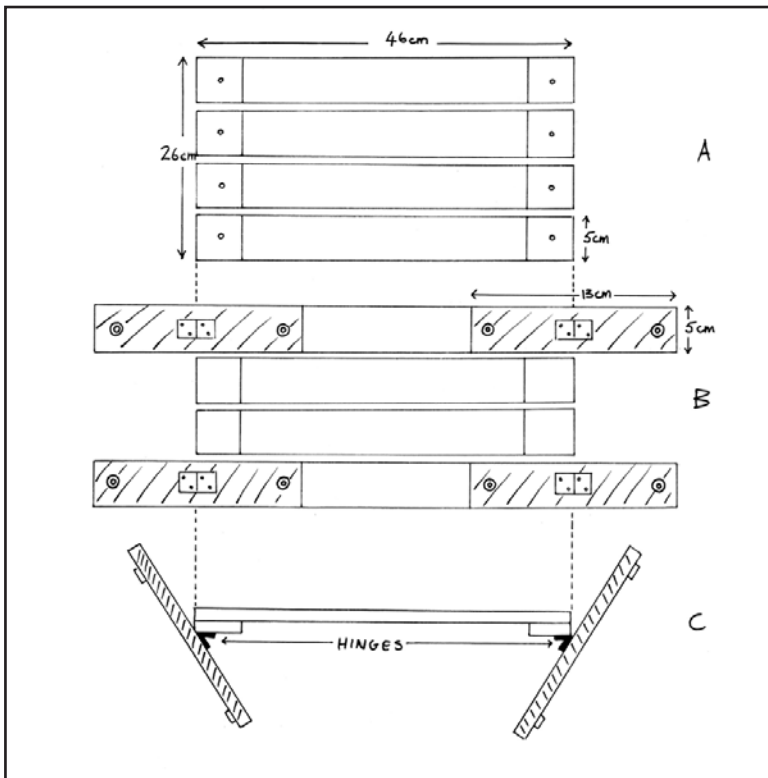

Imilinganiselo kunye neenkukacha ezilandelelanayo zokwakha isitulo sokuhlambela esinemicu.

A. Umzobo wesihlalo.

B. Umzobo wamacala.

C. Indlela yokudibanisa isihlalo namacala.



Ndingamkhokelela njani umntu ebhafini ngaphandle koncedo?

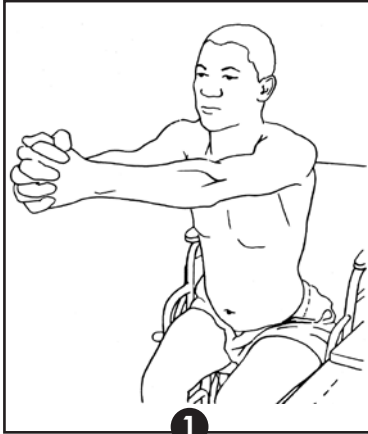

1 Makadibanise izandla kunye aze ame.

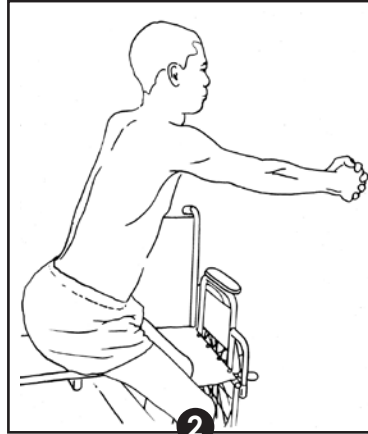

2 Makaguquke aze ahlale ebhokisini yokuhlambela.

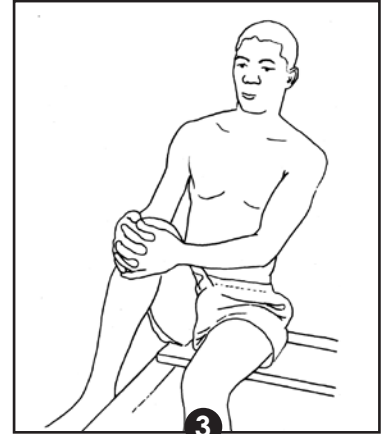

3 Makaxhase umlenze obuthathaka ngamacala onke edolo aze awuphakamise ungene ebhafini.

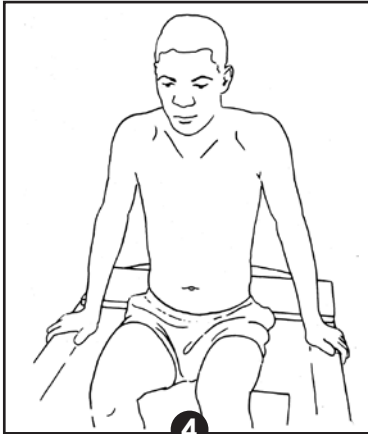

4 Makawutyhalele phantsi ngezandla zakhe awuse phezu komphetho webhafu.

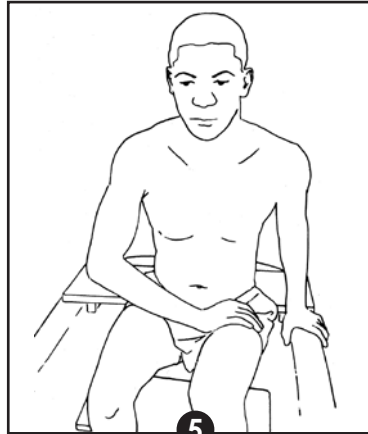

5 Ukuba isandla esibuthathaka sibuthathaka kakhulu, makasibeke kwelinye ithanga aze ehlise umzimba uye ezantsi esitulweni sokuhlambela okanye phakathi ebhafini.



6 Makahlambe umzimba.

Isepha esentanjeni:



- Makenze umngxuma kwisepha. Abophelele isepha entanjeni.
- Makaxhome isepha entanyeni yakhe ukuze ingawi ize ityibilike iye kude.



- Makathi wambu ilaphu emadolweni aze alisimele ngesepha.

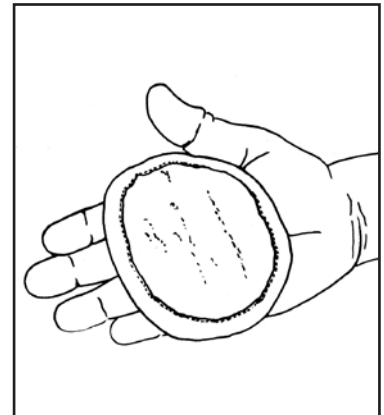

- Makasebenzise isiponji esinelastikhi esifikelela kumva wonke wesandla.

Yenza ibhrashi:

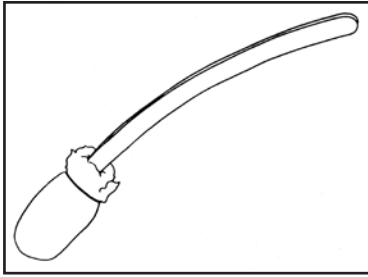

- Makasebenzise ihengari yokuxhoma iidyasi.
- Makajijele isiponji komnye umphetho.
- Makagqume isiponji ngemathiriyeli yetawuli.



Zeziphi izikhokelo endingazilandela ekuncedeni umntu ekunxibeni?

Menze umntu azenzele okuninzi ngokwakhe.

1. Umntu uhlala ekupheleni kwebhedi iinyawo zakhe ziphumle phantsi emgangathweni. Ukuba umntu akakwazi kuzinza ebhedini, menze ahlale esitulweni esinesihlalo esomeleleyo nesinendawo yokuphumza umqolo.
2. Qalisa ngokukhulula, kuba kulula.
3. Sebenzisa impahla enkulu engambambiyo.
4. Sukusebenzisa impahla ekunzima ukuyiqhobosha.
5. Ukunxiba yinqubo ecothayo. Mnike ixesha elaneleyo.
6. Mkhuthaze umntu ngeentetho ezikhuthazayo.
7. Ukuba umntu akwakwazi ukuwenza wonke umsebenzi, wahlule ube ngamanyathelo amaninane, umzekelo ukungenisa iingalo kuphela emikhonweni. Nceda kuphela xa kudingeka.
8. Soloko unxibisa eli cala libuthathaka kuqala uze ukhulule eli cala lomeleleyo kuqala.

Inganxitywa njani ihempe okanye ibhatyi

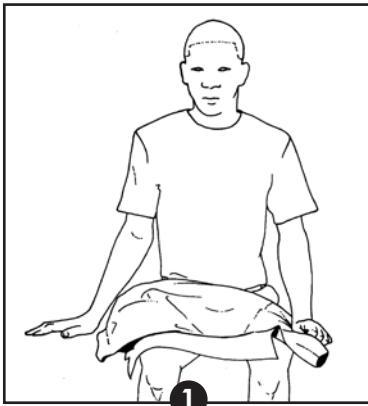

Menze umntu abeke ihempe emathangeni akhe. Umphakathi wehempe ujonge phezulu, ize ikhola ijonge ngasemadolweni. Umkhono wengalo ebuthathaka ujinga phakathi kwemilenze.



Yenza umntu azise ingalo ebuthathaka ngasemathangeni.

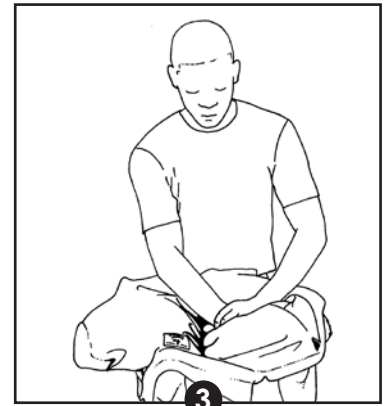

Faka ingalo ebuthathaka kumngxunya ovulekile womkhono.

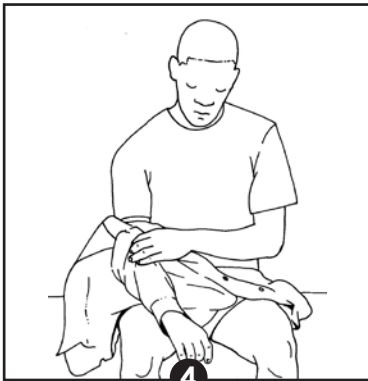

Nyusa umkhono kwisandla esibuthathaka nakwingalo ebuthathaka side isandla sibonakale. Yisa ihempe yonke emqolo.

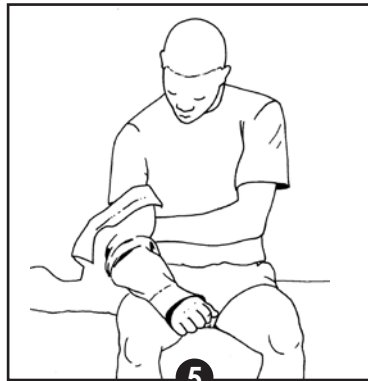

Umntu ngoku wenyusa umkhono uye ngapha kwengqiniba.



Wonyusa umkhono uye phezu kwegxalaba.



Ihempe isiwa kumqolo wonke.

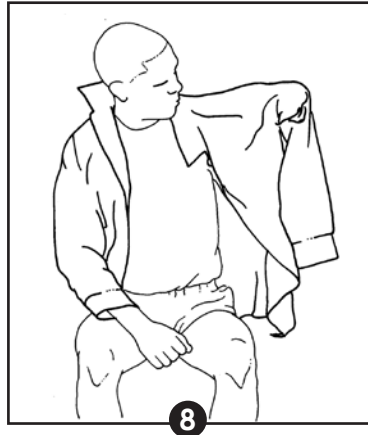

Makafake ingalo yakhe eyomeleleyo kumkhono.

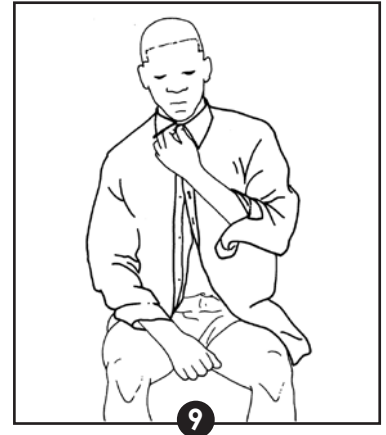

Makaqhoshe amaqhoshha.

Indlela yokunxiba ibhulukhwe



Menze umntu abeke ibhulukhwe kwicala lakhe elomeleleyo.



Unqumlisa umlenze obuthathaka ngaphaya kowomeleleyo.

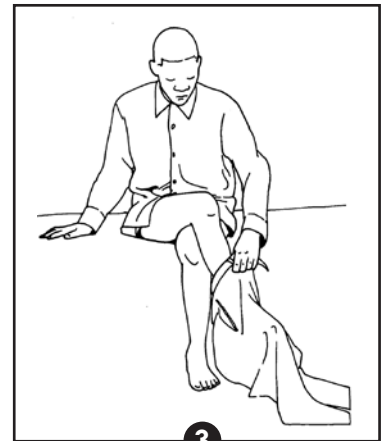

Unyawo olubuthathaka lungena emlenzeni webhulukhwe.



Umntu wenyusa ibhulukhwe ibe phezu kwedolo aze ayeke ukuphithanisa imilenze.



Ngoku unyawo olomeleleyo lungena emlenzeni webhulukhwe.

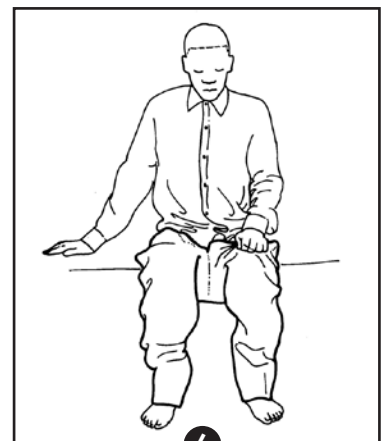

Umntu ngoku wenyusa ibhulukhwe iye ngaphezu kwamadolo.

Ukuba umntu ubuthathaka kakhulu

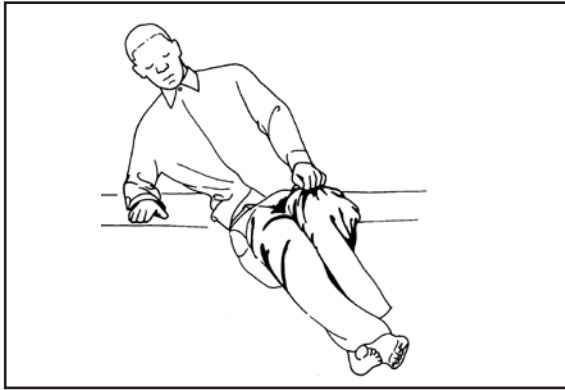

1. Umntu unyusa ibhulukhwe iye ngapha kwemilenze ngokufaka unyawo olomeleleyo ngaphantsi konyawo olubuthathaka, exhaswe egxalabeni, aze alale phezu kwebhedhi.

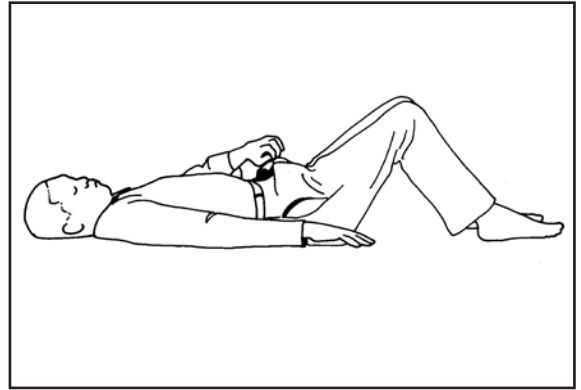

2. Amadolo agotywe.
3. Umntu makaphakamise umzantsi wakhe.
4. Unyusa ibhulukhwe ngaphaya komzantsi.
5. Umzantsi ubuyela ezantsi phezu kwebhedhi.
6. Iziphu nebhanti ngoku zingaqhotyoshwa.
7. Umntu uhlala nkqo kwakhona.

Ukuba umntu angama ngoncedo

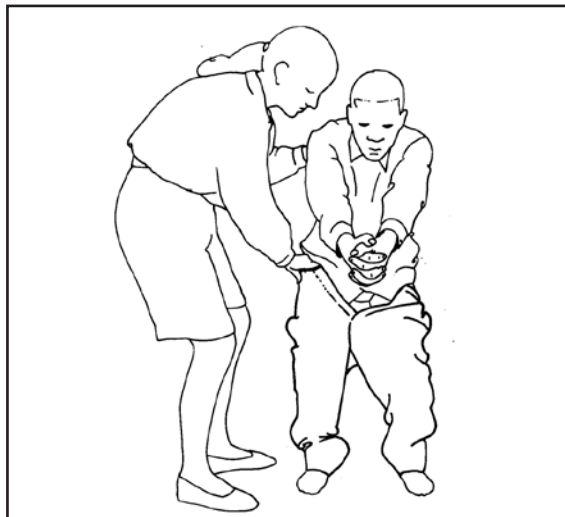

1. Umntu uma ngoncedo (umnonopheli ekwicala elibuthathaka).
2. Umntu angaphumza iingalo kumva wesitulo okanye kwelinye ilungu lefenitshala ukuze akwazi ukuzinza.
3. Umnonopheli unyusa ibhulukhwe.

Ukuba umntu angazimela ngokwakhe

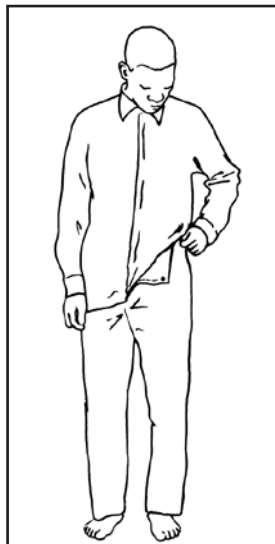

Umntu uyaphakama ukuze enyuse ibhulukhwe yakhe ngaphaya komzantsi wakhe aze aqhoboshe uziphu nebhanti.

Indlela yokunxiba ijezi okanye iswetha



1. Umntu ubeka ijezi yakhe emathangeni akhe, umva ujonge ngakuye isiphelo sona sijonge ngasemzimbeni. Umqala wejezi usemadolweni.



2. Menze umntu avule ijezi ukusuka ezantsi.
3. Ufumana umngxuma womkhono wengalo ebuthathaka.



4. Ufaka umkhono phakathi kwamadolo.
5. Umngxuma womkhono ugcinwa uvulekile ngesandla esomeleleyo.



6. Ingalo ebuthathaka ingena kumngxuma womkhono.



7. Umntu ngoku wenyusa umkhono uye ngapha kwengqiniba.



8. Ngoku wenyusa ngapha kwengalo ephezulu.



9. Ijezi yenyuswa ngapha kwegxalaba.

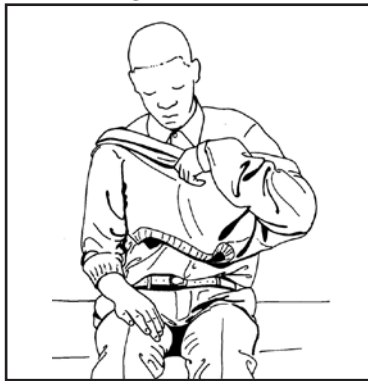

10. Ngoku ingalo eyomeleleyo iyaphumela.



11. Ngoku intloko iyalandela.

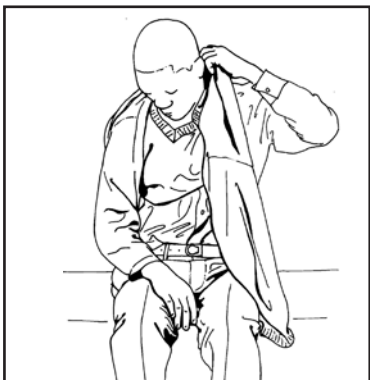

12. Umntu angafaka intloko yakhe kuqala.



13. Emveni koko ingalo eyomeleleyo iyalandela.

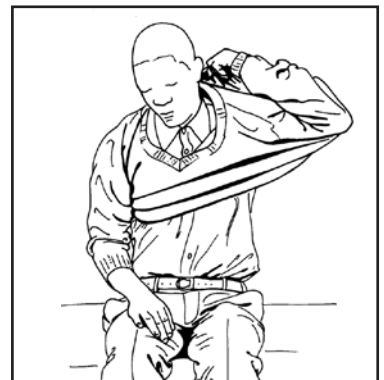

14. Ekugqibeleni wehlisa ijezi ngasemva ukuze akhangeleke kakuhle.

Indlela yokunxiba iikawusi

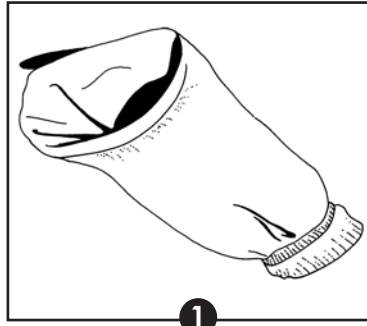

1

Sebenzisa iikawusi ezitsaleka kakhulu. Iikawusi kufuneka isongwe phakathi ukuya ngasemva kwesiciko sesithende.



2

Menze umntu anqamlezise umlenze obuthathaka ngaphaya komlenze owomeleleyo.

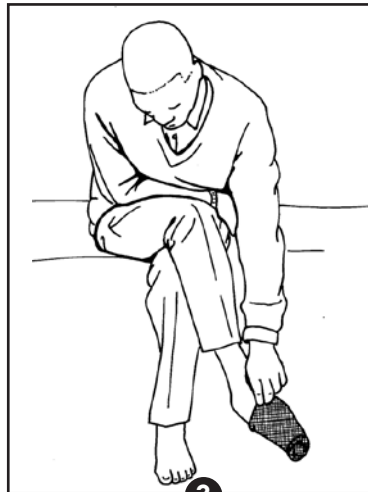

3

Emva koko wenyusa iikawusi ngaphaya kweenzwane.

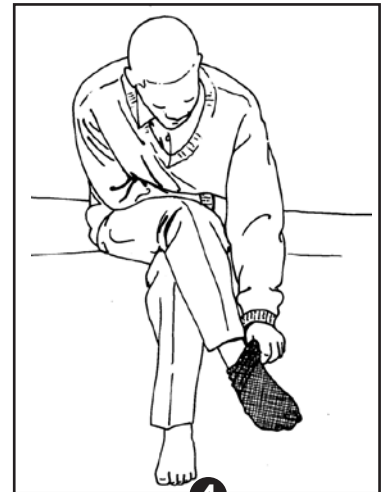

4

Iikawusi ke ngoku itsalwa iye phezu konyawo neqatha.

Indlela yokunxiba izihlangu

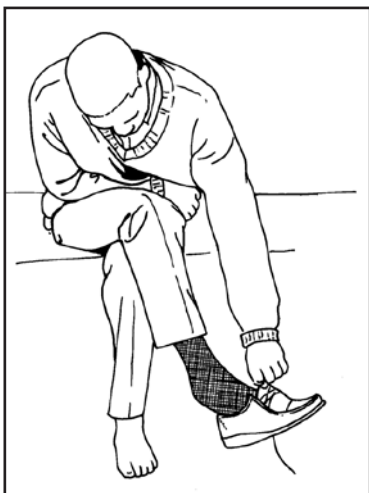

1. Menze umntu anqamlezise umlenze obuthathaka ngaphaya komlenze owomeleleyo.
2. Unyusa izihlangu siye ngaphaya kweenzwane. Sebenzisa izihlangu ezivulekileyo ngasemva okanye izihlangu eziqhotyoshwa ngeVelcro.

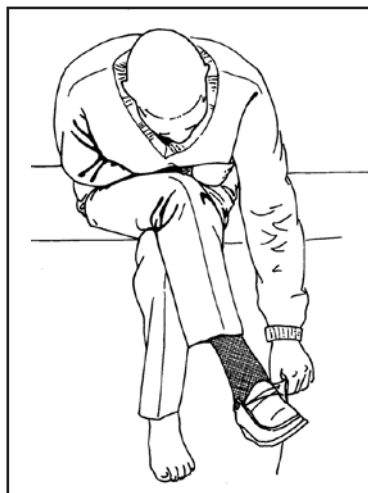

3. Unyawo luyafakwa.

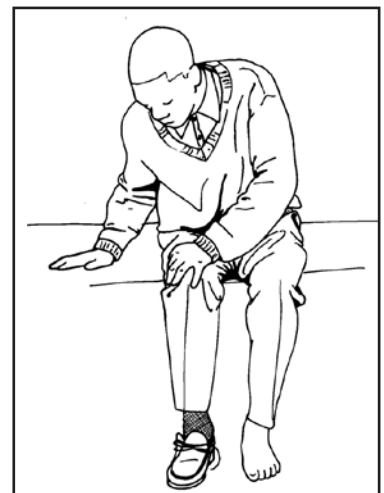

4. Unyawo ngoku lubekwa phantsi emgangathweni aze umntu acinezele edolweni ukuze afake isithende phakathi.

10. Ukuncediswa xa uhamba

? Yeyiphi indlela elungileyo yokunceda umntu ahambe?

Imigaqo ngokubanzi:

1. Xhasa umntu kweli cala libuthathaka.
2. Beka inyonga yakho emva kwenyonga ebuthathaka yomntu.
3. Unyawo lwakho lunganceda unyawo lomntu olubuthathaka, ukuba kuyadingeka.
4. Beka isandla esinye ngokuqinileyo emzimbeni womntu.
5. Esinye isandla sakho sibambe isandla esibuthathaka somntu. Ukuba umntu ubuthathaka kakhulu, beka isandla sakho esingasebenzanga esiswini sakhe ukuze umbambe ngamandla phakathi kweengalo zakho zombini.
6. Nika umntu isithuba sokuba ashukumise umzimba wakhe.
7. Ukuba uma kufutshane kakhulu okanye umbambe ngamandla kakhulu, nobabini niza kusokola ekumeni nkqo kwaye ukuhamba kuza kuba nzima kakhulu.

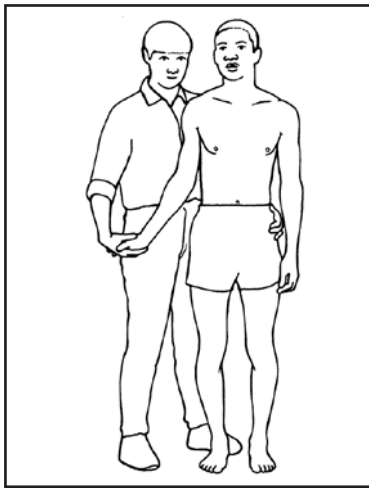

Ukusukela ngaphambili.

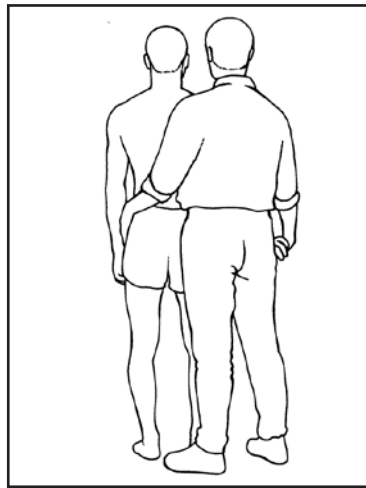

Ukusukela ngemva.



Ukuba umntu ubuthathaka kakhulu sebenzisa intonga yokuhamba kwicala elomeleleyo. Abanonopheli bobabini kunye nomntu lowo mabanxibe izihlangu ezivulekileyo ngasemva ezomeleleyo nabaziva bekhululekile xa bezinxibile okanye bahambe ngenyawo. Sukuhamba ngeekawusi!

Indlela elungileyo yokubambelela:

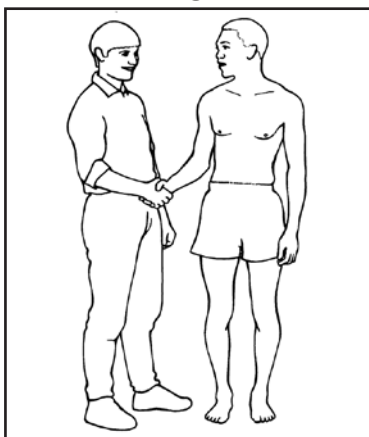

1. Qalisa ngokungathi ungcangcazelisa izandla, kodwa jika intende yesandla ijonge phezu ngexesha ubambe isandla somntu.
2. Bamba isandla esibuthathaka.
3. Sukutsala ingalo ebuthathaka.

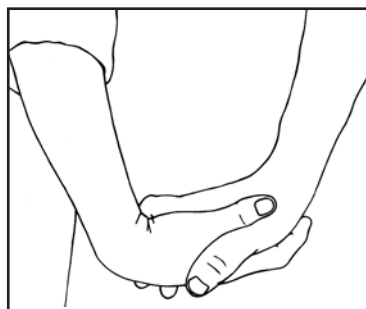

4. Xhasa ingalo ngokucinezela usiya phezu ngesandla.
5. Gcina ingqiniba yomntu ithe nkqo ngasemzimbeni wakho. Ngale ndlela, ingalo ihlala ithe nkqo kwaye umntu angoyama kwisandla sakho ukuze axhaseke. Oku kukwamnceda ahlale nkqo.

Enye indlela yokubambelela:

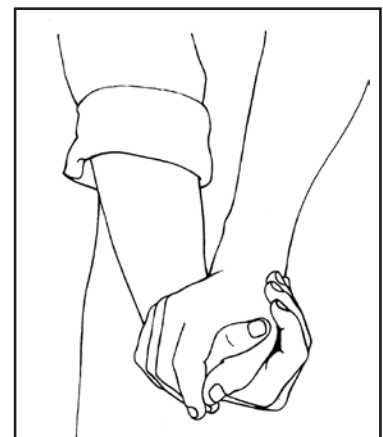

- Le yindlela elungileyo yokubambelela ukuba umntu unezihlahla ezinqinileyo.
1. Hakisha oobhontsi bakho kunye.
 2. Bamba isandla somntu kumzantsi kabhontsi.
 3. Qinisekisa ukuba umntu akeva zintlungu esihlahleli sakhe.

11.

lingxaki eziqhelekileyo emva kwesifo sokufa icala

Ingxaki	Funa uncedo ku-	Igama neenkukacha zomniki-nkonzo kwinda-wo yakho
lintlungu zegxalaba/iintlungu zegxalaba nez-esandla	Umntu onyanga umzimba ngokwenzisa imithambo/Ugqirha onceda ekubuyiseleni ukwazi ukusebenza	
Usulelo kumbhobho woku-chama (isinyi)	Iklinikhi/ugqirha/ umongikazi	
Ukuqunjelwa/ukuhambisa	Iklinikhi/ugqirha/umongikazi	
Ukutyibilika okanye ukophuka kwesitulo esinamavili.	Iklinikhi ekuhlalwayo kuyo/ingcali yomsebenzi enoqeqesho lwezitulo ezinamavili kunye nokuhlala kuzo/Umntu onyanga umzimba ngokwenzisa imithambo/Ugqirha onceda ekubuyiseleni ukwazi ukusebenza	
lingxaki zokuziphatha	Ugqirha onceda ekubuyiseleni ukwazi ukusebenza/ugqirha wezengqondo onyangayo/unontlalo-ntle	
Ukutsalwa kolwelo (ukukhameka okanye ukukhohlela emva kokuginya)	Ingcali yokunyanga ukuthetha/ umongikazi	
Izilonda zebhedi	Iklinikhi/ugqirha/ umongikazi kunye nomntu onyanga umzimba ngokwenzisa imithambo/ugqirha onceda ekubuyiseleni ukwazi ukusebenza	
Ukunciphisa imisipha/ukuqina kwemisipha / kwenkantsi yemisipha	Umntu onyanga umzimba ngokwenzisa imithambo	
Ukudakumba	Iklinikhi/ugqirha/ugqirha onceda ekubuyiseleni ukwazi ukusebenza/unontlalo-ntle	
Ukubona kabini okanye ukubona kwicala elinye kuphela	Iklinikhi/Ugqirha wamehlo/ Ugqirha onceda ekubuyiseleni ukwazi ukusebenza	



Qinisekisa ukuba abantu ababenesifo sokufa icala bathatha amayeza abo amiselweyo.

Imibulelo

Ababhali bangathanda ukubulela aba bantu balandelayo, ngaphandle koncedo lwabo olu xwebhu ngelungakhange luphumelele:

1. UJenny Hendry, oqalise le projekthi, wancediswa kukukhuthazwa ngenkxaso-mali, ud- lale indima enkulu kakhulu ngexesha lokuqulunqa, waze wanika izimvo zakhe ngexe- sha lokuhlela kokugqibela.
2. UGubela Mji ngokuthabatha iprojekthi ku-Jenny Hendry kunye nokunika inkuthazo en- gapheliyo.
3. UDeona Roets ngegalelo lakhe kwicala lokuthetha nokuginya.
4. Icandelo laseTygerberg lamaZinyo ngokunika imiboniso nolwazi olumalunga non- akekelo lwamazinyo nomlomo.
5. U-Andrienne Human, umthabathi-zithombe ngomonde wakhe nangokuba ngumntu othanda izinto ezichanekileyo zafezekiswa.
6. Imizekelo yemizobo yemigca: Ngu-Neels Olivier, no-Jeanette Oliphant, no-Christa Prins, no-Deona Roets, no-Lynette Vorster, no-Elizabeth Brandt, no-Susan Human, no-Maria Britz kunye noMandy Smith.
7. Isebe lobuGcisa: Ikhampasi yase-Tygerberg, iYunivesithi yaseStellenbosch ngemizobo yomgca wokuqala.
8. UKim McDonald ngongqinelwano lwemizobo yemigca kunye nangokulunga nokuchaneka aye waqhubeka nako ukusukela kumagcisa angaphambili.
9. USheena Irwin-Carruthers, uHelen Sammons noJacqui Goeller ngokuhlela imveliso yokugqibela.
10. Abantu ababenesifo sokufa icala, iintsapho zabo kunye nabanonopheli babo ngezim- vo zabo ngexesha lokuphuhlisa le projekthi.
11. Abathabathi-nxaxheba bezifundo zabadala zonyaka wama-2010 zekhosi yabantu abadala iBobath esisiseko abathabatha inxaxheba kwinkqubo yokuhlola oogxa babo.

Umbulelo owodwa uya kwi-Boehringer Ingelheim ngokuxhasa ngemali uhlelo noguqulo lonyaka wama-2015 ukuya kwiilwimi zesiBhulu, isiSuthu, isiXhosa nesiZulu.



**Boehringer
Ingelheim**



Kutheni sibhale le ncwadana?

Isifo sokufa icala sisigulo esinzima, kwaye ukunonophela umntu onesifo sokufa icala ngumceli - mngeni. Okwenza le meko ibe nzima kakhulu kukuba kukhona iinkonzo ezimbalwa kakhulu zasekuhlaleni zokubuyisela kwimeko yesiqhelo ezifumanekayo. Abantu abaninzi abangeniswa nokungeniswa esibhedlele emva kokuba nesifo sokufa icala, kwaye abo bangeniswayo baqhele ukukhutshwa ngaphakathi kweeyure ezingama-48.

Abanonopheli basekhaya kunye nabanonopheli ngokubanzi abaqeqeshwanga ngendlela eyiyo kwaye abaxhaswa, kwaye kufuneka bamelane nemeko kangangoko banako. Abanonopheli bayasokola ekunxibelelaneni nomntu kwaye abasoloko beziqonda iingxaki zokuziphatha ezenziwa sisifo sokufa icala. Bakufumana kunzima ukunceda umntu onesifo sokufa icala ngemisebenzi yomzimba efana nokunxiba kunye nokudlulela kwenye indawo. Oku kukhokelela kwiingxaki, ezinokunqandwa lula xa kuthethwa inyani, ezifana namagxa nezandla ezibuhlungu, iinkantsi kunye neendlela zokwenza zesiqhelo ezimbi.

Ngowe-1995, inkxaso-mali yafunyanwa kwaPortnet njengenxalenye yesiCwangciso soHlengahlengiso noPhuhliso sabo ukuze kwenziwe umgodlo woqeqesho, owawuquka inkqubo yoqeqesho yeeyure ezine yabanonopheli base-makhaya kunye namanye amaziko anonophelayo, anje ngamakhaya abantu abadala, kwakunye nencwadana yoqeqesho eyayigxininisa imiba ephathekayo ekwakuthethwa ngayo ngexesha lokwenza uqeqesho. Lo mqulu wokuqeqesha waveliswa ngenzame edibeneyo liZiko leziFundo zokuBuyisela kwimo yesiqhelo leYunivesithi yaseStellenbosch kunye neZiko laseNtshona Koloni lokuBuyisela kwimeko yesiqhelo.

Ngaphaya kweminyaka elishumi, iye yacokiswa kwaye yalungiswa ngokweemfuno ezixeliweyo nangezimvo ezifunyenweyo ezisuka kubaqeqeshi nakubantu ababenesifo sokufa icala. Ukulunga kolu xwebhu kwavavanywa njengenxalenye yezifundo zeemastazi ngu Gqr Janine Botha. Iingcebiso ezimalunga nesi sifundo zenziwe nazo. Incwadana egqityiweyo iyafumaneka ngoku.

Ababhali bayathemba ukuba le ncwadana iza kunika isikhokelo esilula nesifikelekayo kubanonopheli ukuze isetyenziswe njengento ekungajongwa kuyo ekhaya. Ayenzelwanga ukuthabatha indawo yoqeqesho, kodwa yenzelwe ukuba isetyenziswe ngabanonopheli ekuzikhumbuzeni emva kokuba belugqibile uqeqesho lwabo. Abanonopheli kufuneka bachithe ixesha elililo kuqeqesho ukuqinisekisa ukuba banezakhono ezizizo nezifanelekileyo.

Icandelo leziFundo zokuBuyisela kwimeko yesiqhelo, eYunivesithi yaseStellenbosch

Iziko leziFundo zokuBuyisela kwimeko yesiqhelo lenza iinkqubo zezifundo ezingaphaya kwesidanga (MSc/Mphil) kubuyiselo kwimeko yesiqhelo kwiingcali ezisuka kwiziza zempilo nezinxulumene nazo. Indlela ekwenziwa ngayo yedibanisa iziza ngeziza, kugxininiswa kuphuhliso lwezakhono zobunkokheli ukuze kwenziwe lula uphuhliso, ulawulo novavanyo, kwakunye nophando kwiinkqubo ezizizo nezingaxabisi kakhulu zokubuyisela kwimeko yesiqhelo nezokhubazeko. Iziko leziFundo zokuBuyisela kwimeko yesiqhelo likwadlala indima exhasayo kuphuhliso loludwe lwezifundo ngaphakathi kweFakhalthi yamaYeza neeNzululwazi zeMpilo ngokumayelana nemiba enxulumene nokhubazeko nokubuyisela kwimeko yesiqhelo.

Eli ziko lifana lodwa ngokunikeza imfundo ebanzi yokubuyisela kwimeko yesiqhelo kunye neenkqubo zoqeqesho, amathuba ophando nenkonzo kuzo zonke iinzululwazi zempilo nakwiingcali zemfundo yokubuyisela kwimeko yesiqhelo kumanqanaba onke eenkonzo zempilo ekuhlaleni.

<http://www.sun.ac.za/crs>

Iziko laseNtshona Koloni lokuBuyisela kwimeko yesiqhelo kubaNtu abaKhubazeke ngokoMzimba.

Iziko laseNtshona Koloni lokuBuyisela kwimeko yesiqhelo lizinikele ekubuyiseleni kwimeko yesiqhelo eyiyo nelungileyo ebantwini abakhubazeke ngokomzimba. Senza iinkqubo ezibanzi zokubuyisela kwimeko yesiqhelo kwizigulane ezingaphakathi/ngaphandle esibhedlele ukukhuthaza intatho-nxaxheba epheleleyo eluntwini. Iimpawu zeenkonzo zethu ziquka indlela yokwenza engqonge kubaxhasi nesekelwe kwiziphumo kunye nentsebenziswano yamaqela adibanisa iziza zezifundo ezahlukeneyo.

I-WCRC inomlinganiselo weebhedi ezili-156 zezigulana ezingaphakathi. Kungeniswa abaxhasi abasuka kwiimeko ezinzima zezibhedlele zikarhulumente nezabucala ngoko nangoko xa kukho ukuzinza empilweni yabo kwaye bayakwazi ukuthatha inxaxheba kwiinkqubo zethu zokubuyisela kwimeko yesiqhelo. Inkonzo yezigulana ezisuka ngaphandle kwesibhedlele iquka uvavanyo/uqwalaselo, ulandelo lokubuyisela kwimeko yesiqhelo, iiklinikhi ezithile kunye namanyathelo okuqala okufikelela ngaphandle.

Umbono we-WCRC kukuba yinkokheli ehlabathini ekubuyiseleni imeko kwisiqhelo kubantu abakhubazeke ngokomzimba.

<http://www.wcrc.co.za>

