



Stellenbosch
UNIVERSITY
IYUNIVESITHI
UNIVERSITEIT

Engineering
EyobuNjineli
Ingenieurswese



Environmental & Biological Diagnostics: The Engineering Perspective

Dr Taskeen Ebrahim – Electrical and Electronic Engineering

Faculty of Engineering

Industry Showcase 2026

SAND Research Group and NMMF

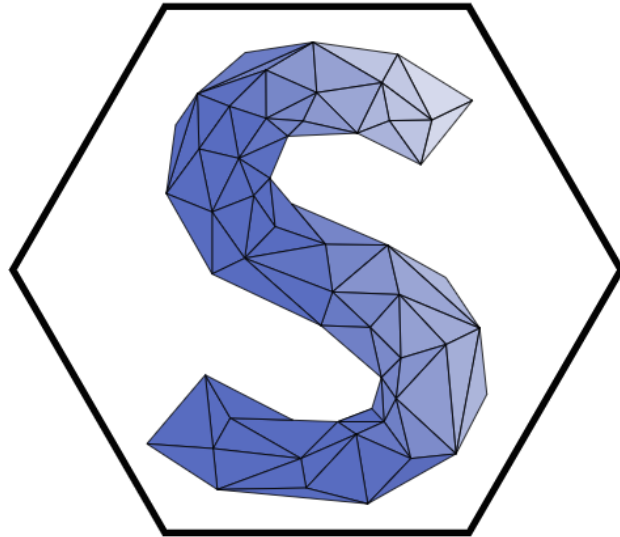

SAND

Sensor Application and Nano Devices



nano-micro
manufacturing
facility

nmmf.co.za

**Director of Biosensors Node, hosted at
Stellenbosch University:**

Prof. Willem Perold (wjperold@sun.ac.za)

Lab manager:

Mr Daniel Retief (jdretief@sun.ac.za)

Why biosensing?

- Used in medical diagnostics, environmental monitoring, food safety, and biosecurity.
- Reduces the need for expensive laboratory tests, making healthcare more accessible.
- Can detect low concentrations of analytes with high precision, ensuring accurate diagnostics.
- Provides real-time data, allowing for timely interventions and adjustments in treatment plans.
- Possibility of continuously tracking health indicators without invasive procedures.

Common Commercial Sensors



Glucometer



Pregnancy tests



Drug panel



COVID Ag tests



Breathalyzer

What is a biosensor?

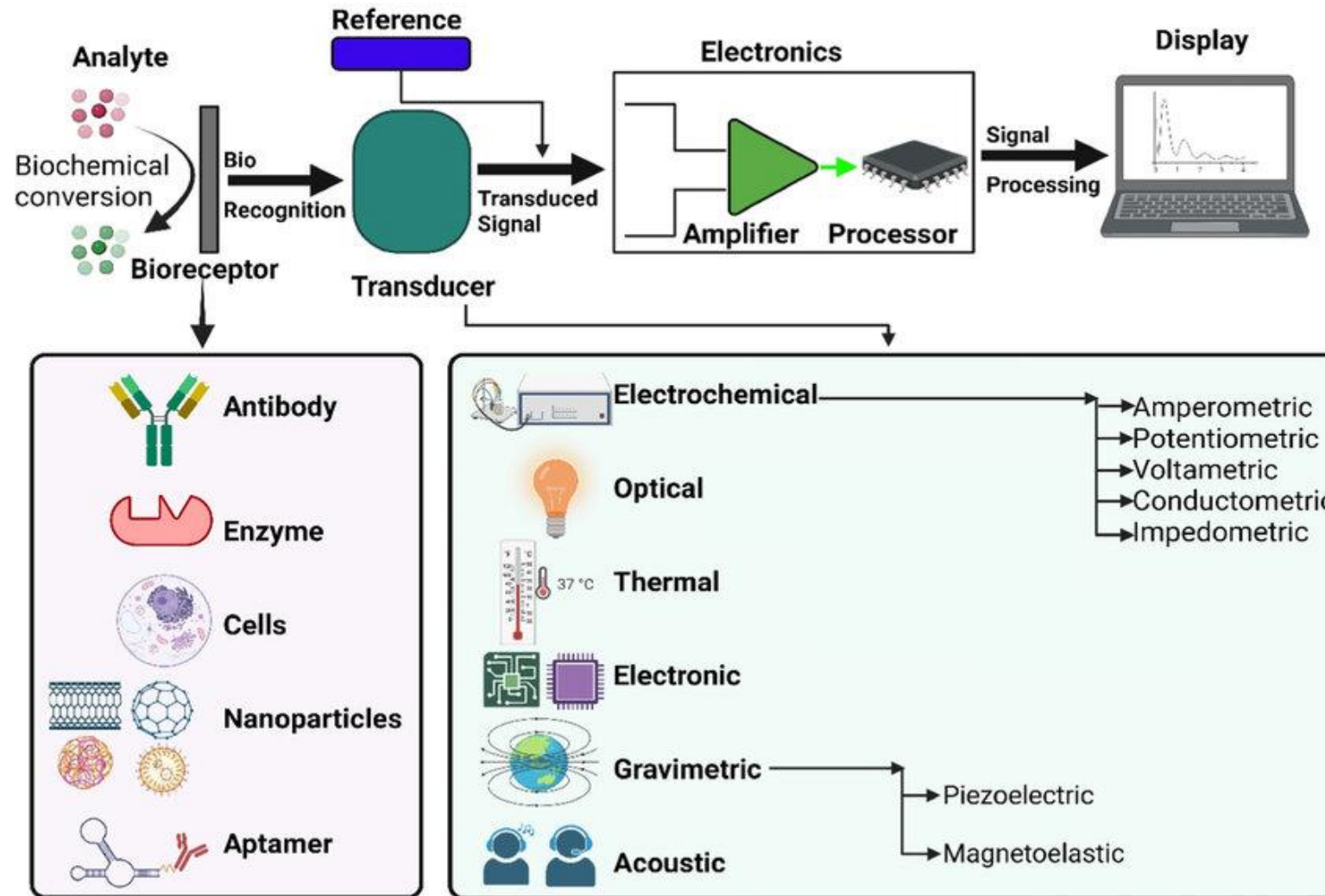

Active multidisciplinary projects

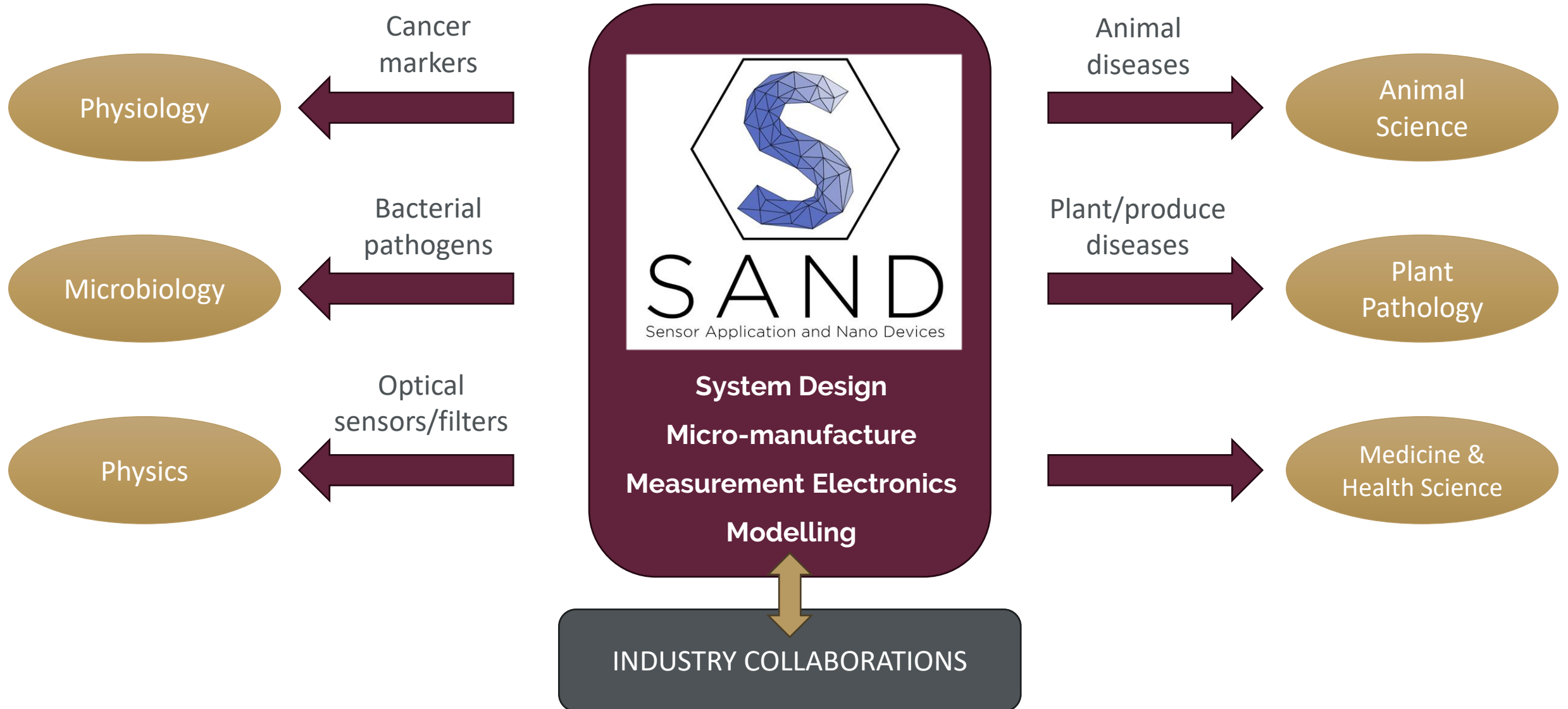

Biology/Environmental Sensor Related Work

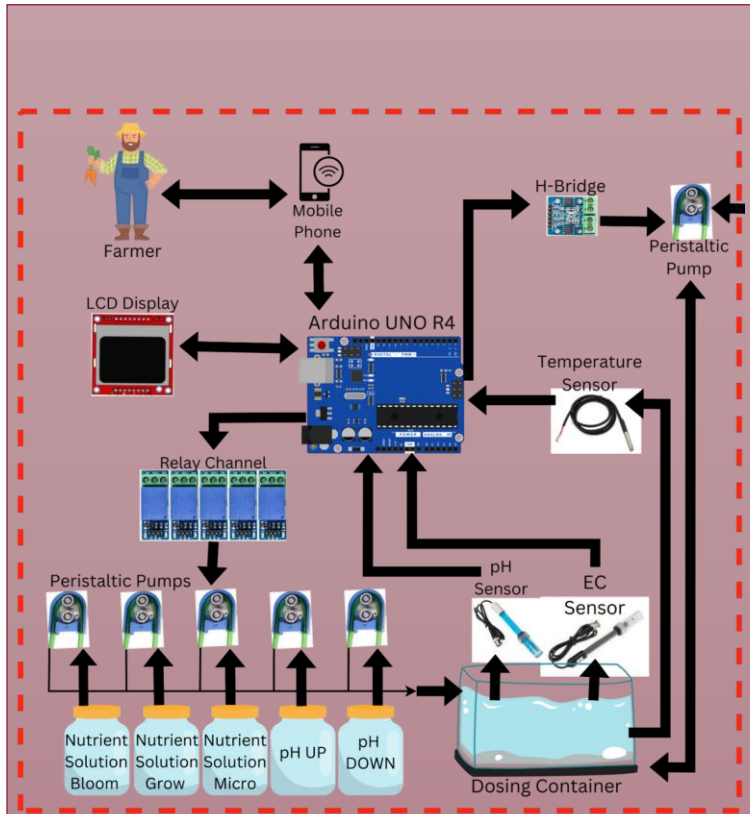

Hydroponics system
automated dosing

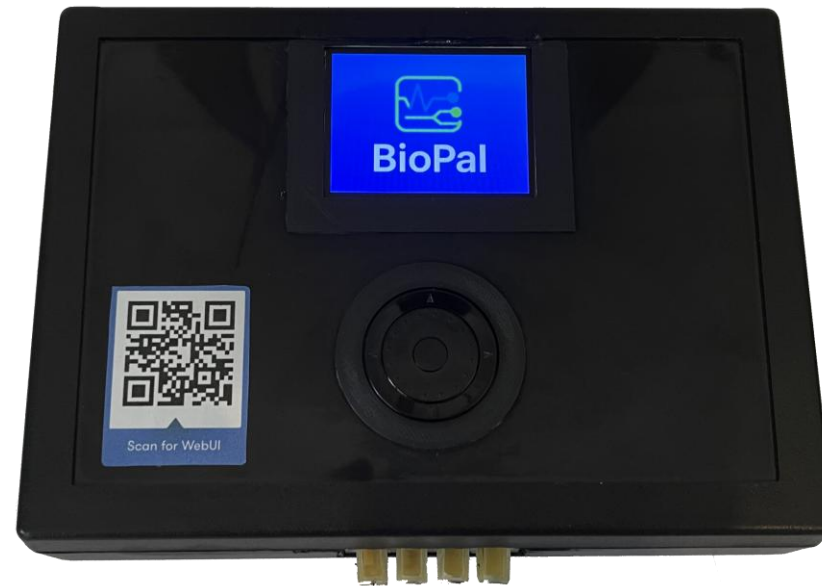

Design and prototyping:
measurement electronics
systems



Microfluidic bioreactor
development

Physics Related Work

- Low-cost flow cytometer
- Quantum optical measurement development,
 - Coupling problem – ultrafine diffraction gratings,
 - Biosensors with single-molecule sensitivity.
- Optical ring resonator development,
- Optical circuitry development,
 - Logic gates, true random-number generation,
- Novel spectrometer biosensor system,
- Fluorescence-based biosensors

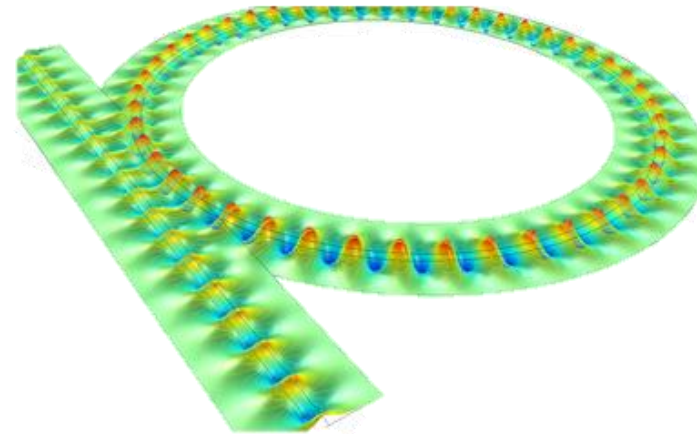

Optical ring resonator

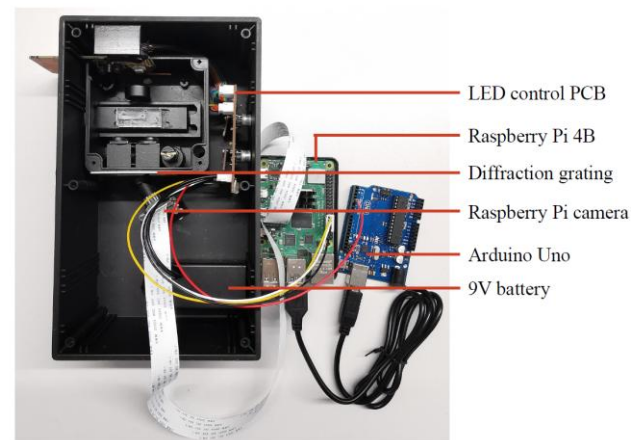

Low-cost spectrometer

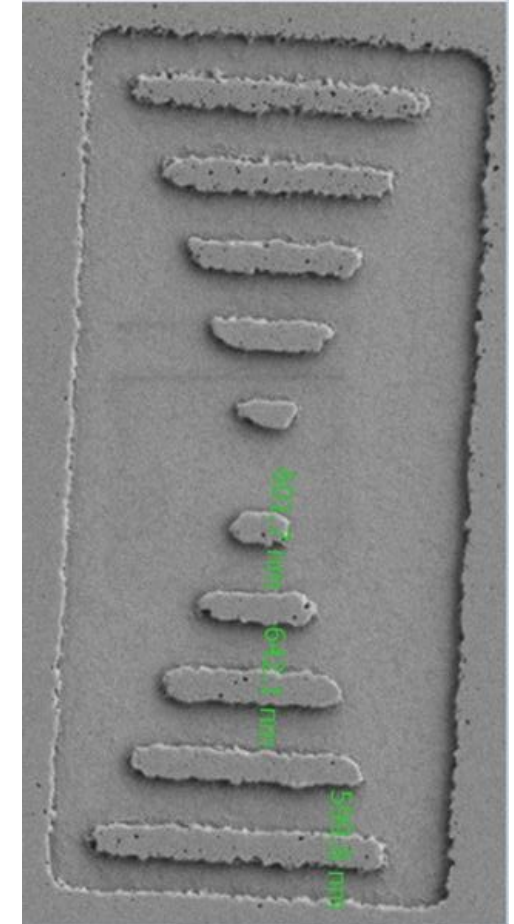

Diffraction grating

Sensor Surface Modifications

Henniker Plasma HPT-200
(with dual gas inlets and a special chamber to allow etching)



Relevant Plasma Treatments



Plasma Cleaning of Optics & Lenses

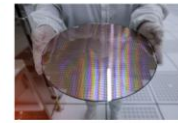

Plasma Cleaning prior to Spin Coating

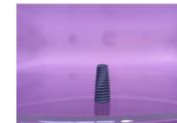

Plasma Surface Treatment for Dental Applications



Plasma Treatment of Medical Devices

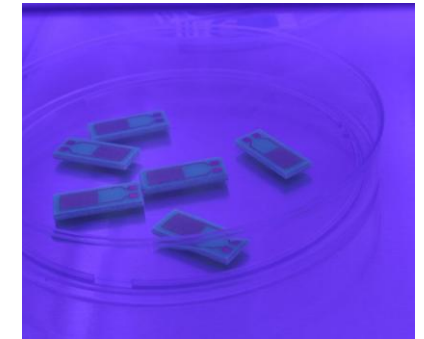

Plasma Treatment of PDMS for Microfluidics



Plasma Treatment prior to Wire Bonding

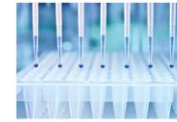

Plasmas in Life Science Applications

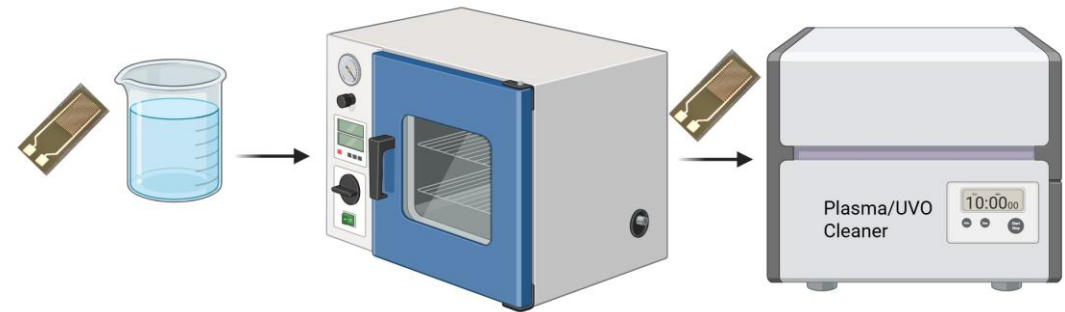

<https://plasmatreatment.co.uk/products-services/our-models/hpt-100-hpt-200>

Equipment & Facilities

PalmSens4 Electrochemical Interface

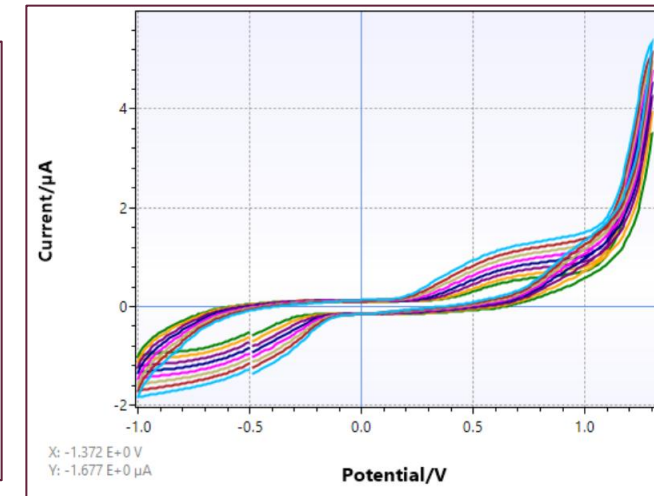
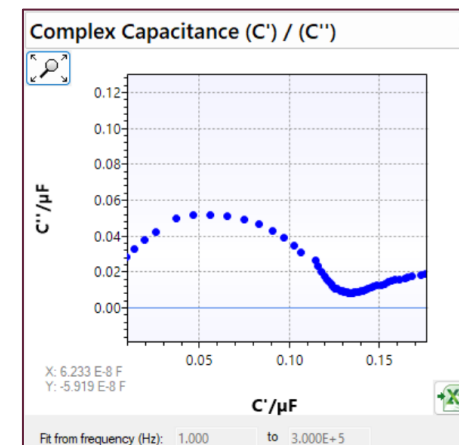
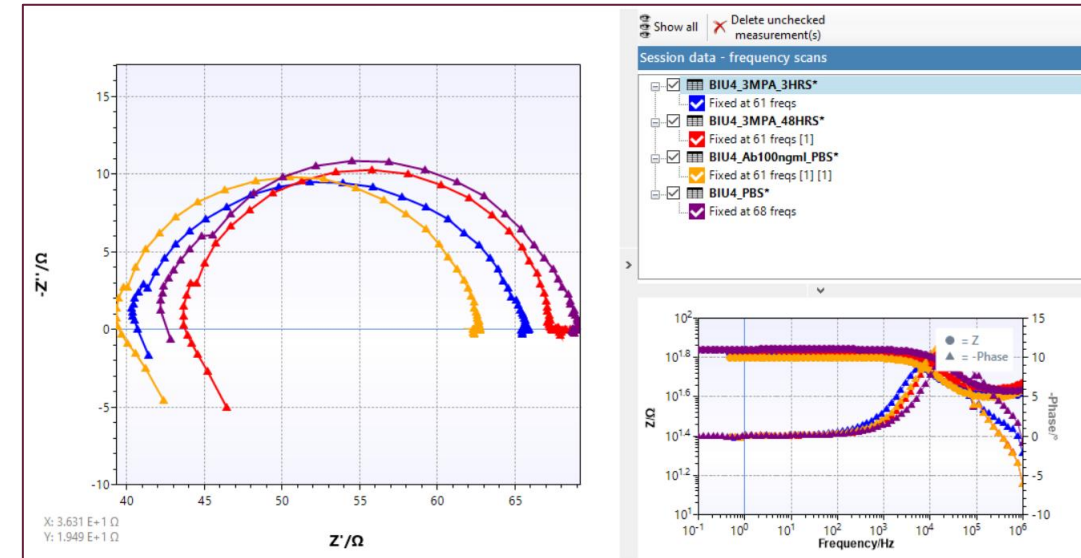
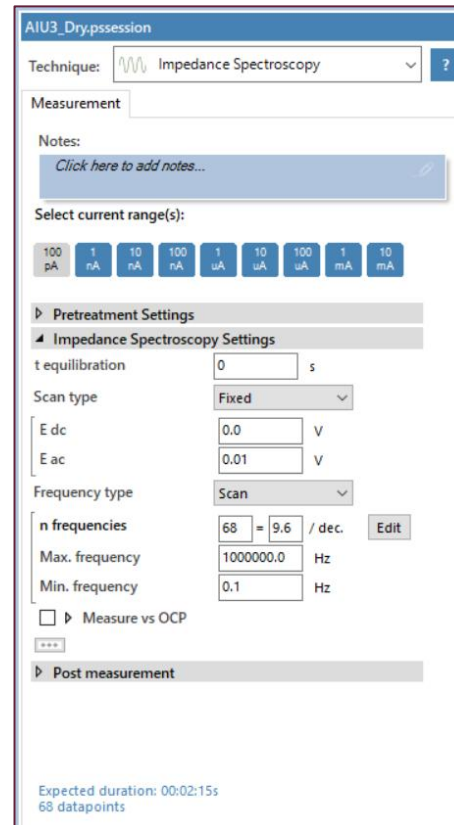

<https://www.palmsens.com/product/palmsens4/>

Durham Magneto Optics ML3 Mesa (with dual wavelength light source)

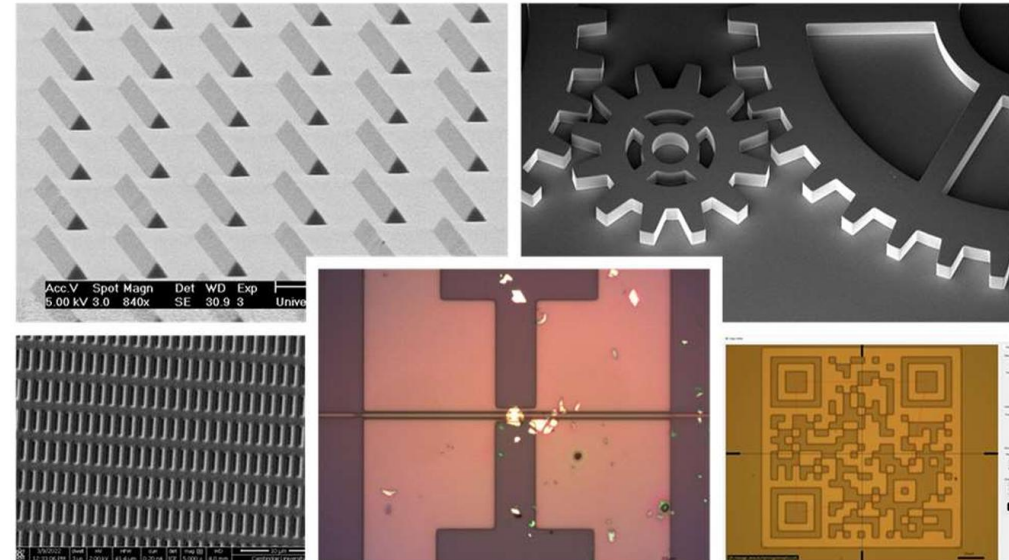

- 1 μ m resolution with <math><0.1 \mu\text{m}</math> layer alignment accuracy,
- Ultra-high write speed,
- Automated process inspection functionality.

<https://www.durhammagnetooptics.com/?product=microwriter-ml3-mesa>

Equipment & Facilities

Microfluidics development and more:

Asiga MAX X27 Resin 3D printer

Laser cutter

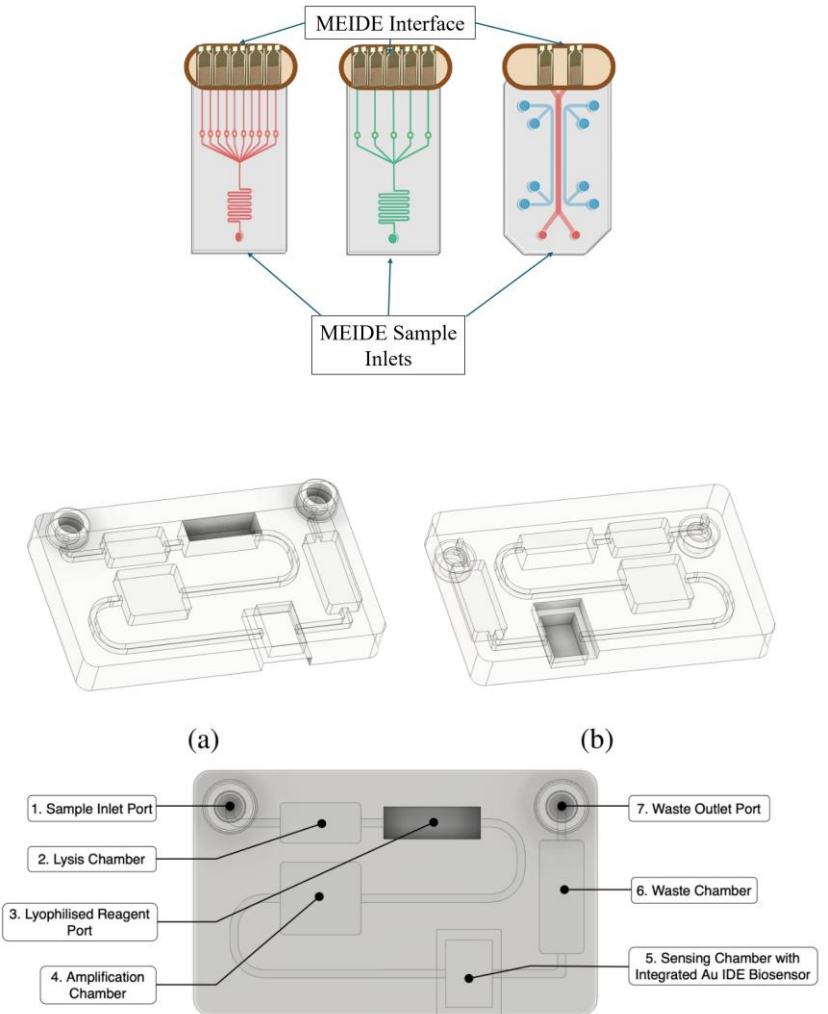
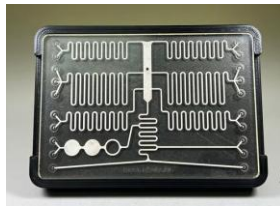

<https://www.asiga.com/max-x/>

COMSOL Multiphysics

COMSOL
MULTIPHYSICS®



Multiphysics Software for Simulating Real-World Designs, Devices, and Processes

COMSOL Multiphysics®

It all starts with COMSOL Multiphysics®, the platform product for creating physics-based models and simulation applications. COMSOL Multiphysics® includes the Model

- COMSOL is the standard for our Multiphysics models
- Heat-transfer, wave-optics, electrochemistry, design, microfluidics and AC/DC modules for simulation of biosensors of any kind

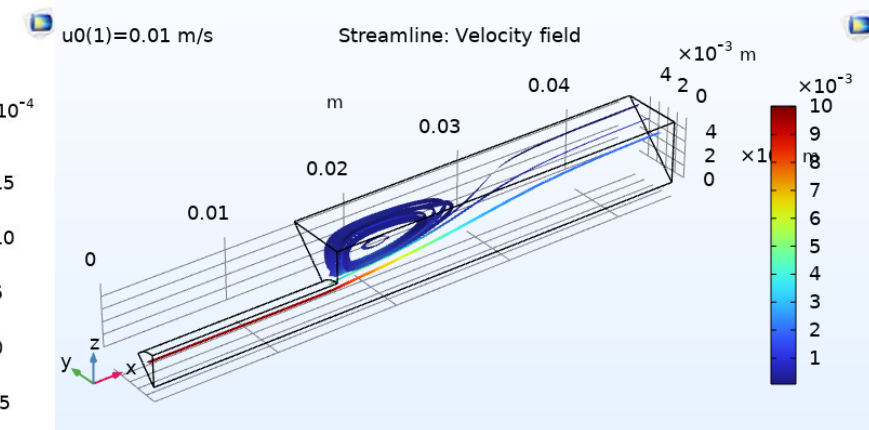
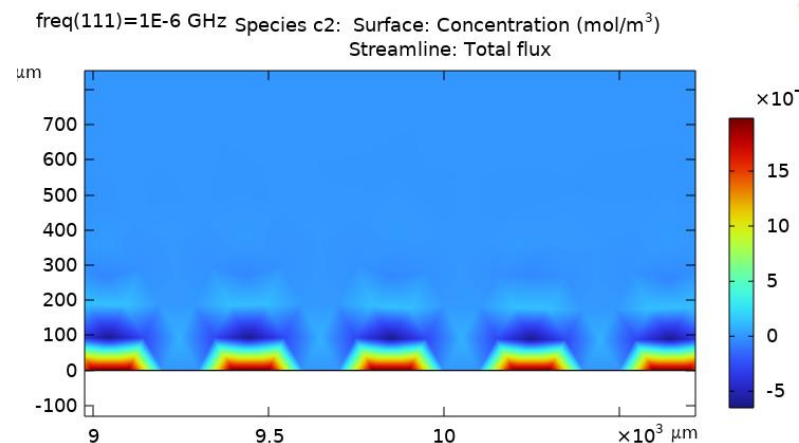

Angstrom Nexdep Platform (customized to perform e-beam evaporation)



<https://angstromengineering.com/products/nexdep/>

Our specifications:

- Sequential multi-material deposition,
- Ultra-uniform coating with redundant measurement,
- High-speed cycle times - max 30m pump down,
- Cryo-cooling system with temperature control between 0 °C and 300 °C,
- Custom substrate holder to deposit up to 4x 5" wafers or 2x6" wafers simultaneously.

Equipment & Facilities – COMING SOON

ISO Certified Laboratories and Cleanroom

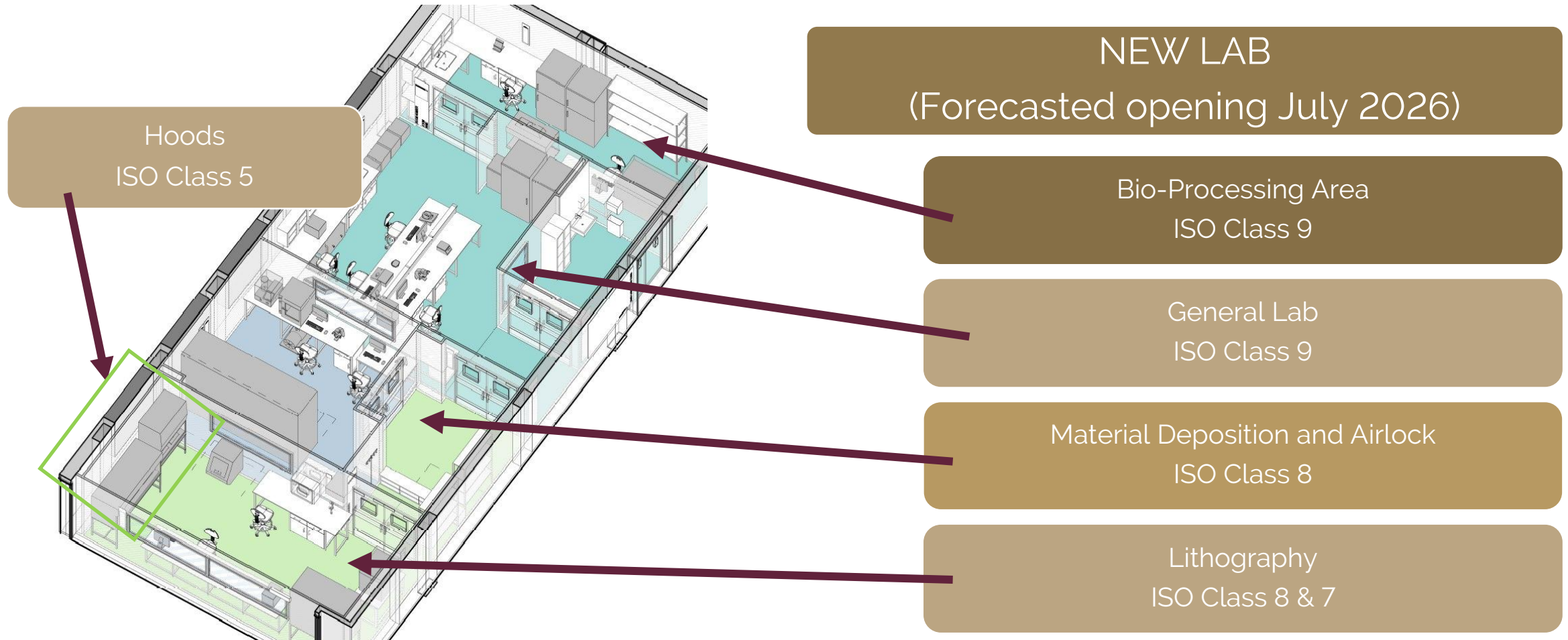



Stellenbosch
UNIVERSITY
IYUNIVESITHI
UNIVERSITEIT

Engineering
EyobuNjineli
Ingenieurswese

Thank you
Enkosi
Dankie