



Stellenbosch
UNIVERSITY
IYUNIVESITHI
UNIVERSITEIT

Data Analytics for Process Engineers

Data in Industrial Processes (practice)

- Industrial datasets are:
 - Dynamic (autocorrelated)
 - Low volume
 - Noisy, missing, censored, faulty
 - Low observability
- Render traditional approaches ineffective
- Advantage:
 - Often amenable to simulation

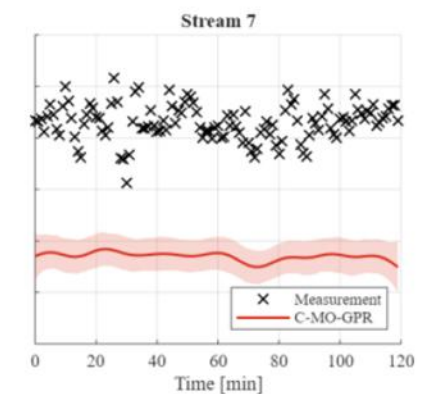
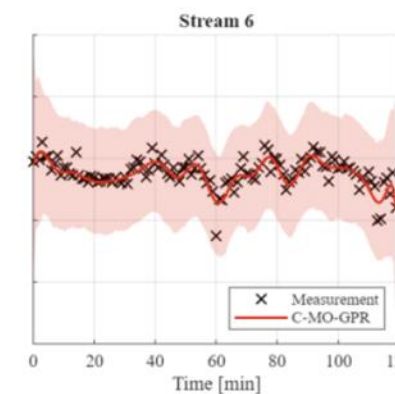
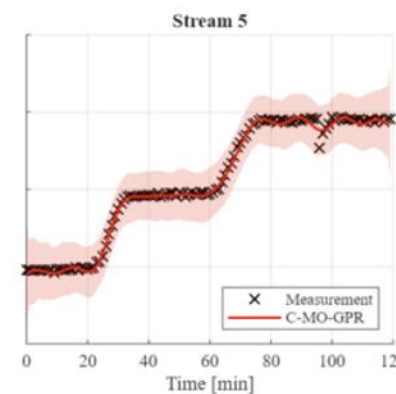
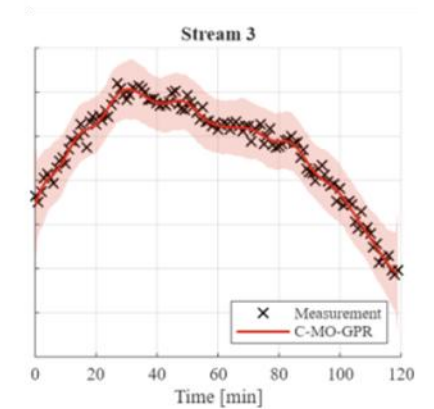
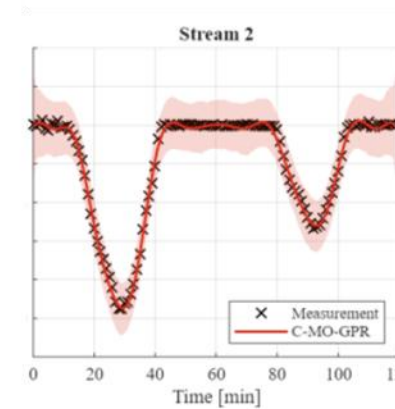
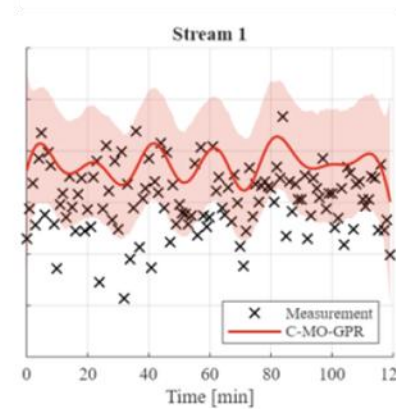

Data in Industrial Processes (research)

- ML/AI research space has become increasingly difficult to navigate
- Incredibly fast-moving field, with disproportionate amount of bad publications
- Falacy of generally applicable solutions (especially in process engineering)
- Hype...

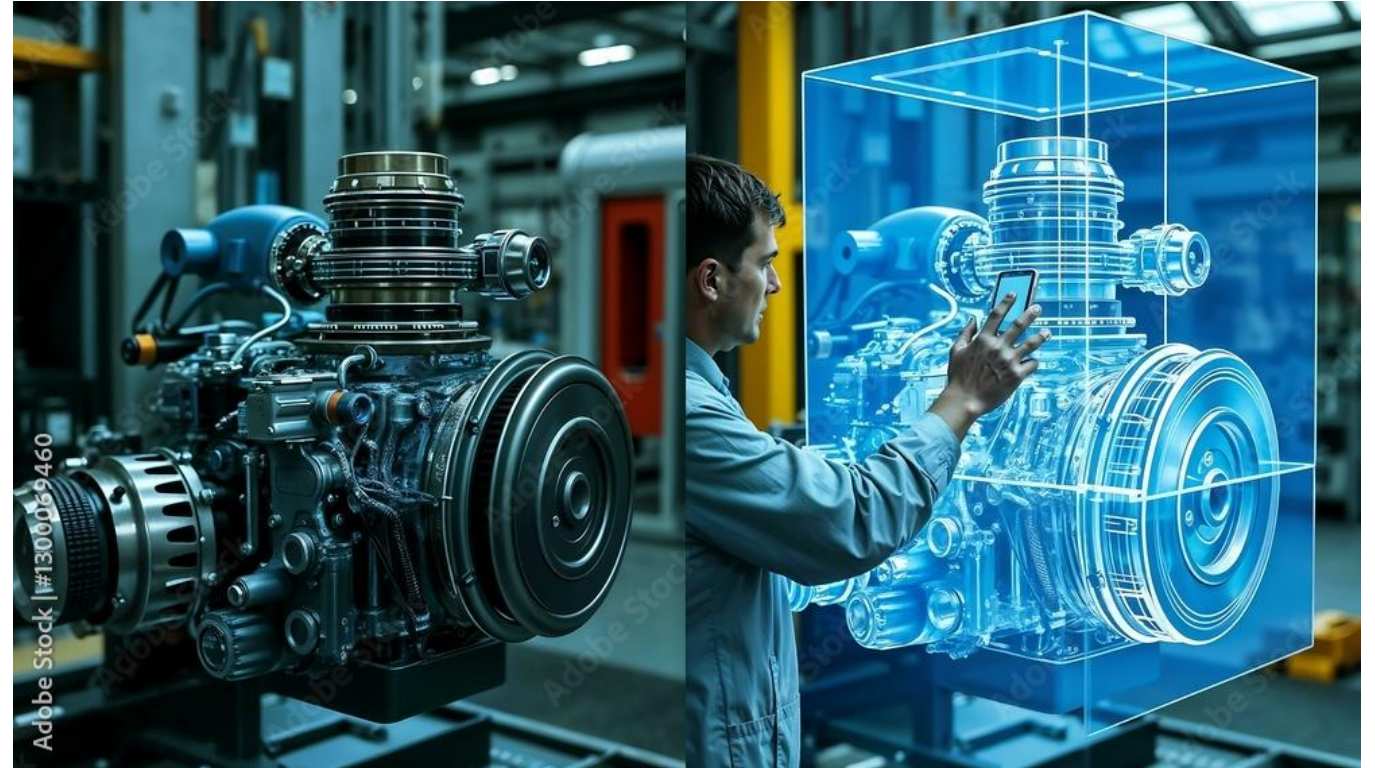

Our approach

Process
understanding,
simulation and
control
informed by
first-principles

Our approach

Process
understanding,
simulation and
control
informed by
first-principles

- Development, implementation and validation of advanced process models remains a valued skill in industry
- First-principles modelling enables understanding of operating principles
- Effective use of existing models/libraries/tools is essential

Our approach

Conceptual
understanding
of mathematical
and statistical
fundamentals

Our approach

- Application of ML tools is easier than ever
- Limited understanding limits usefulness of results (junk in = junk out)
- Mathematically and statistically rooted understanding of ML tools enables effective application *and critique*

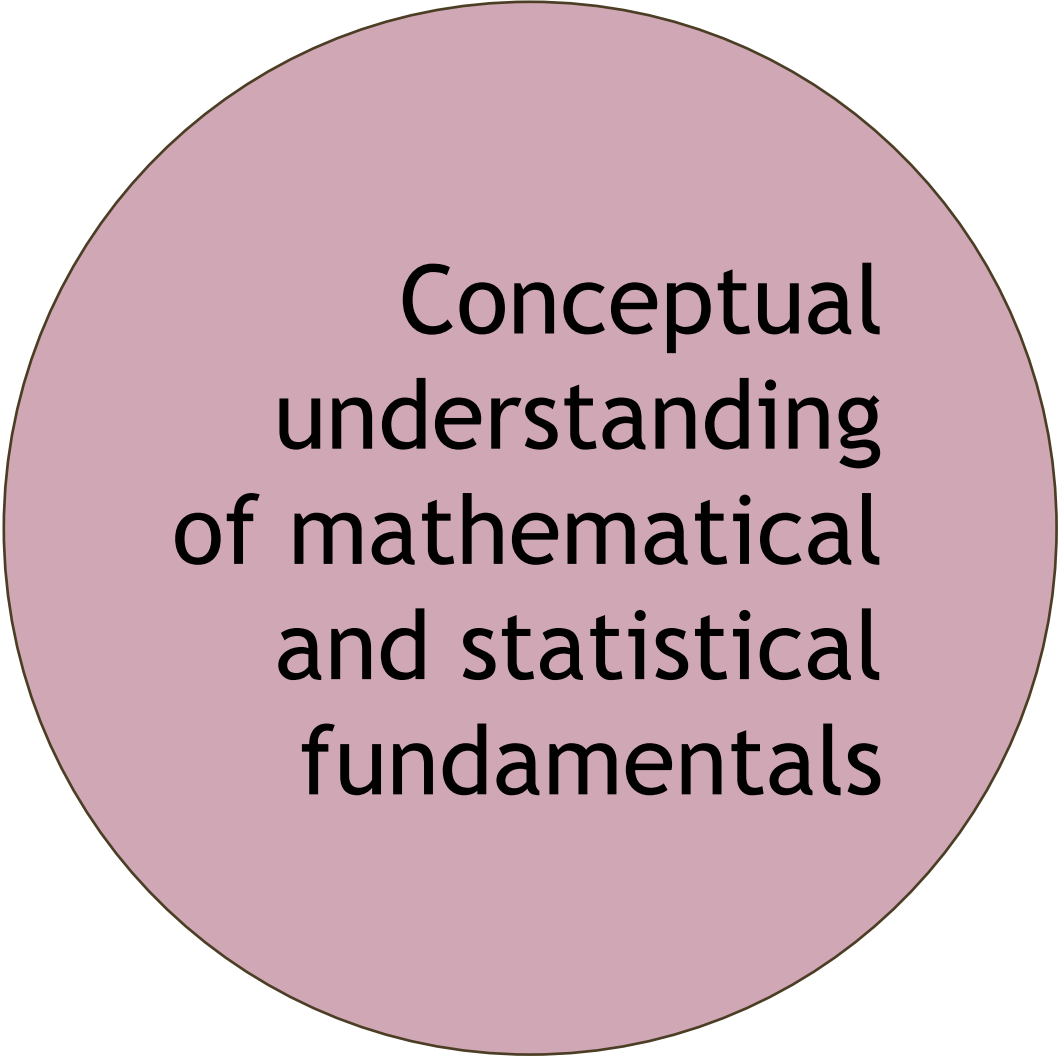

Conceptual
understanding
of mathematical
and statistical
fundamentals

Our approach

Process
understanding,
simulation and
control
informed by
first-principles

Conceptual
understanding
of mathematical
and statistical
fundamentals

Our approach

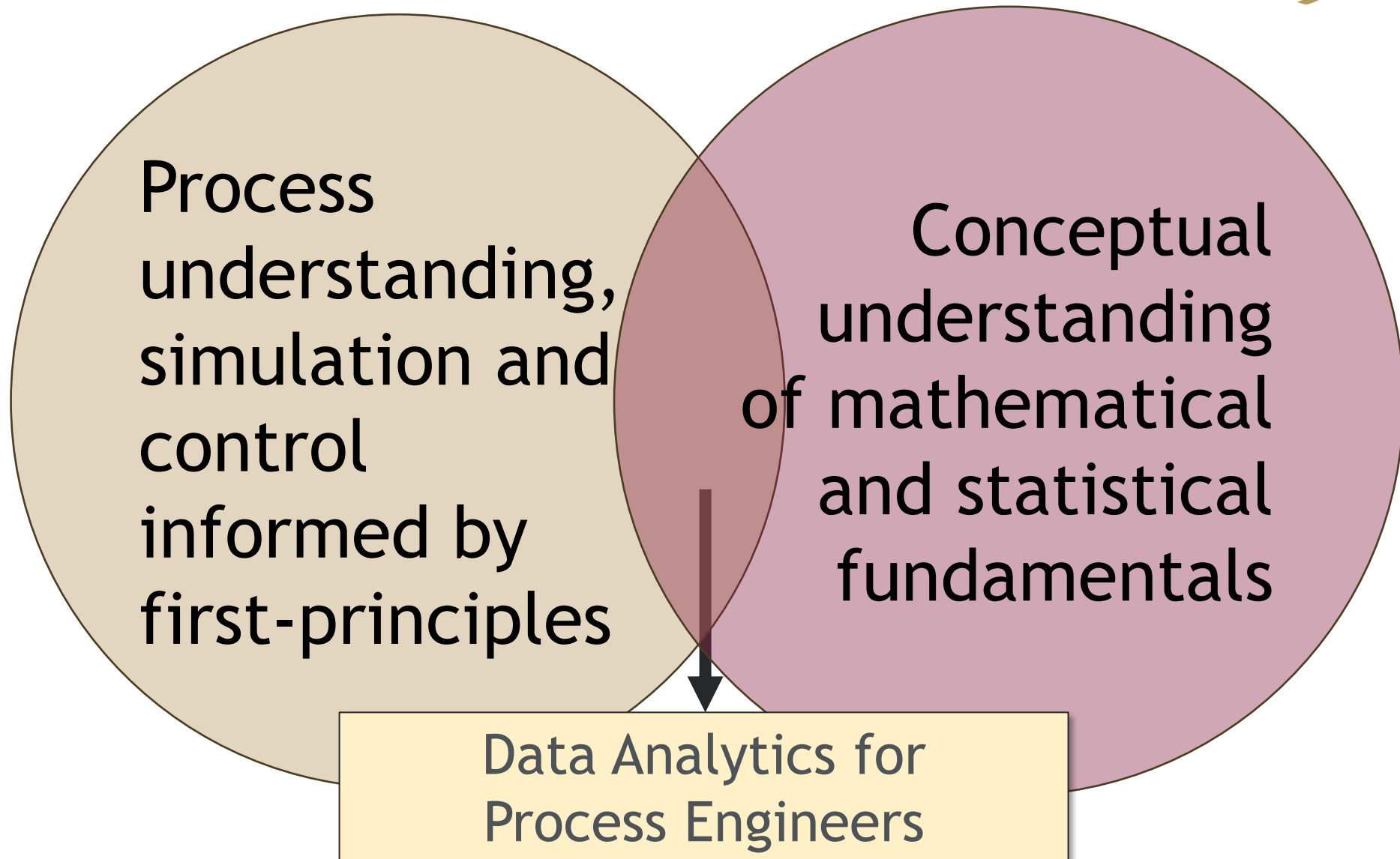

Our approach: capacity development



Post-doctoral
Research

- Provides direct industry-academia link
- Quick turnaround times by experienced researcher
- Investigate ideas that are difficult to find time for

Our approach: capacity development

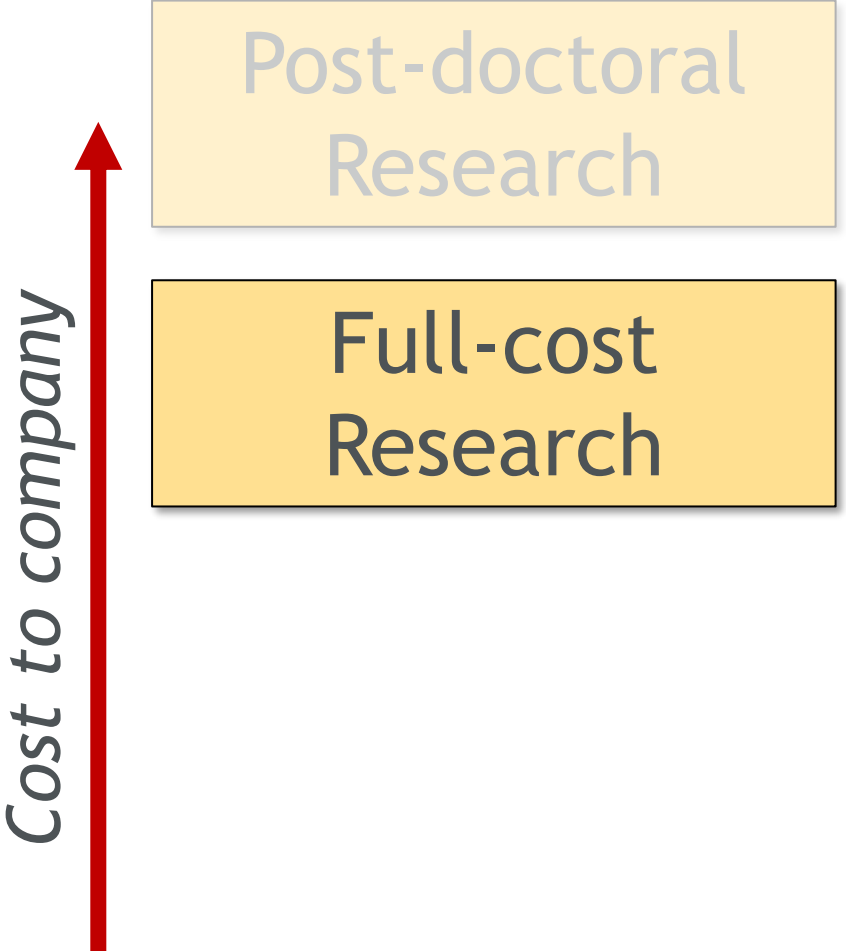

Post-doctoral
Research

- Provides direct industry-academia link
- Quick turnaround times by experienced researcher
- Investigate ideas that are difficult to find time for

Full-cost
Research

- Well-defined research project with clear deliverables
- Frequent interaction through steering committee
- 2 years (MEng) - 3 years (PhD)

Our approach: capacity development

Cost to company



Post-doctoral
Research

- Provides direct industry-academia link
- Quick turnaround times by experienced researcher
- Investigate ideas that are difficult to find time for

Full-cost
Research

- Well-defined research project with clear deliverables
- Frequent interaction through steering committee
- 2 years (MEng) - 3 years (PhD)

Bursary
sponsorship

- Limited influence on exact research project, typically specified in broad terms
- Skill development dependent on supervisor

Our approach: capacity development

Cost to company ↑

Post-doctoral
Research

- Provides direct industry-academia link
- Quick turnaround times by experienced researcher
- Investigate ideas that are difficult to find time for

Full-cost
Research

- Well-defined research project with clear deliverables
- Frequent interaction through steering committee
- 2 years (MEng) - 3 years (PhD)

Bursary
sponsorship

- Limited influence on exact research project, typically specified in broad terms
- Skill development dependent on supervisor

Structured MEng
programme

- Specifically designed for part-time students (i.e., existing employees) working in simulation / analytics
- Fully online, hybrid learning

Mathematical Modelling and Machine Learning (Chemical Engineering)

- Collaboration with researchers in extractive metallurgy, paper-and-pulp, green hydrogen, separations technology, etc.
- Full-time:
 - Two post-docs
 - Three PhD students
 - Four Masters students
- Part-time:
 - 44 students in structured Masters program
 - First cohort (16 students) to graduate in March 2027





Structured Masters in Chemical Engineering, focus area: Data Analytics

Data Science

Applied Machine Learning

Plantwide Dynamics and Control

Advanced Topics in Engineering Management

Year 1



Structured Masters in Chemical Engineering, focus area: Data Analytics

Numerical
Methods

Optimisation

Dynamic Process
Data Analytics

Integrated
Process Data
Analytics

Year 2

Data Science

Applied Machine
Learning

Plantwide
Dynamics and
Control

Advanced Topics
in Engineering
Management

Year 1



Structured Masters in Chemical Engineering, focus area: Data Analytics

Research Project

Year 3

Numerical
Methods

Optimisation

Dynamic Process
Data Analytics

Integrated
Process Data
Analytics

Year 2

Data Science

Applied Machine
Learning

Plantwide
Dynamics and
Control

Advanced Topics
in Engineering
Management

Year 1



Structured Masters in Chemical Engineering, focus area: Data Analytics

- Why Plantwide Dynamics and Control?
 - Engineers must develop an intuition regarding process causality
 - Control systems have a major impact on process data e.g., constraints, shifting variability, steady operation
 - Fundamentals relevant to data analytics are well-established in Advanced Process Control, e.g., state estimation, MPC

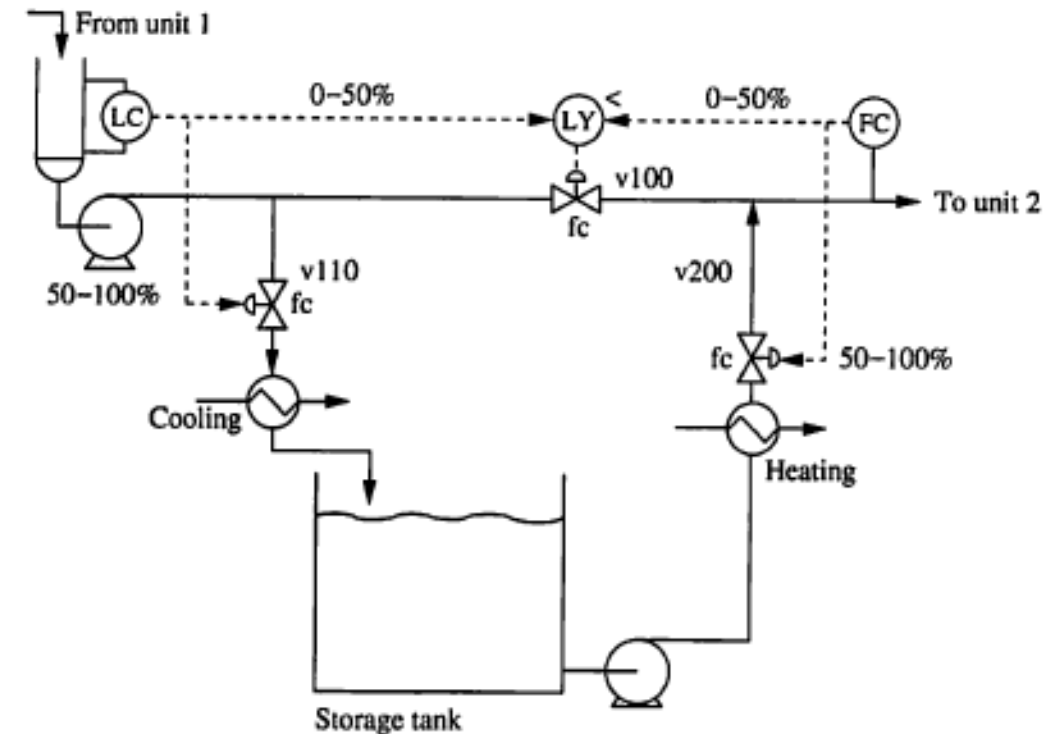



Structured Masters in Chemical Engineering, focus area: Data Analytics

- Why Dynamic Process Data Analytics?
 - Time series data introduces a host of challenges as well as opportunities, requiring adaptation of common ML tools
 - Fundamentals concepts such as Dynamic Embedding and Observability enable critical analysis of forecasting tools
 - Introduce well-established methods for “physics informed machine learning”, e.g., Kalman Filtering

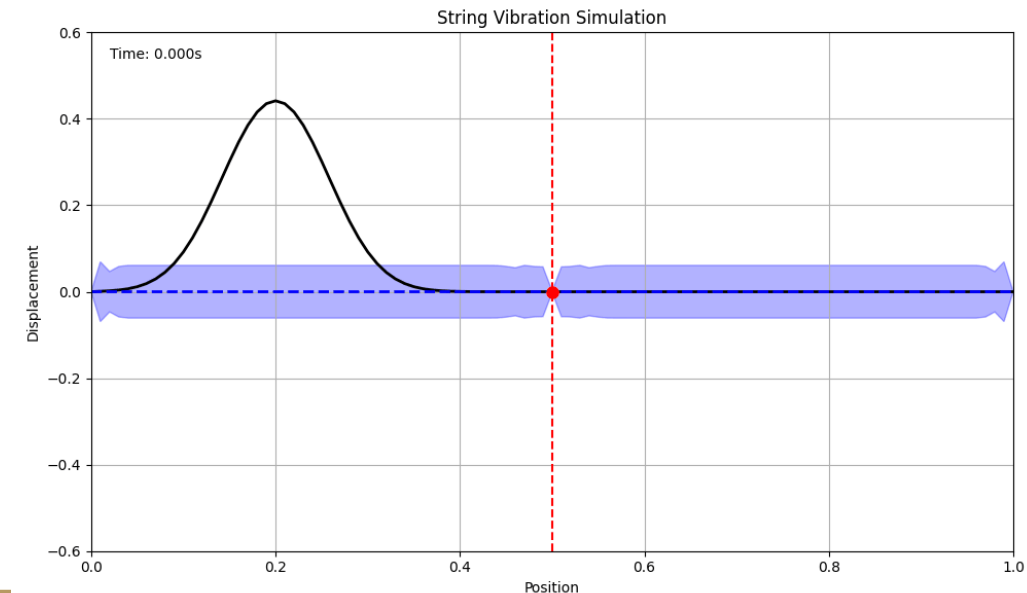
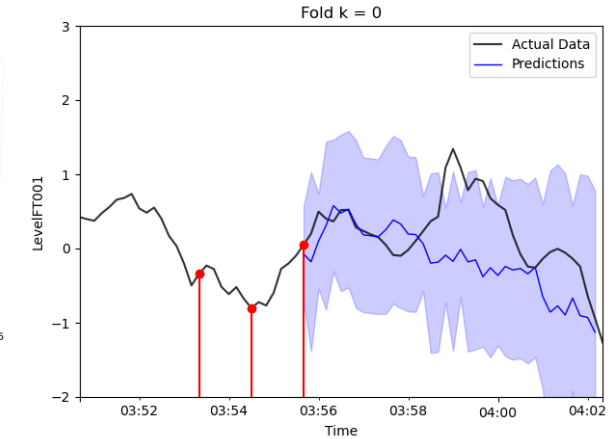
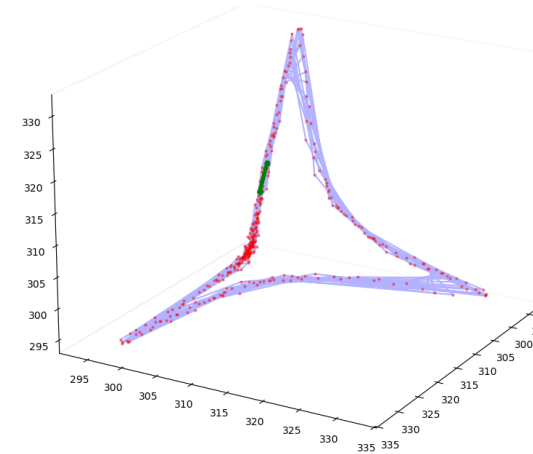



Structured Masters in Chemical Engineering, focus area: Data Analytics

- Why Integrated Process Data Analytics?
 - Consider the entire Data Analytics Project lifecycle, from economic benefit estimation to post hoc performance analysis
 - Host of guest lectures introducing current industry best practice
 - Integrate data-driven intervention into the business plan to encourage wide-spread adoption

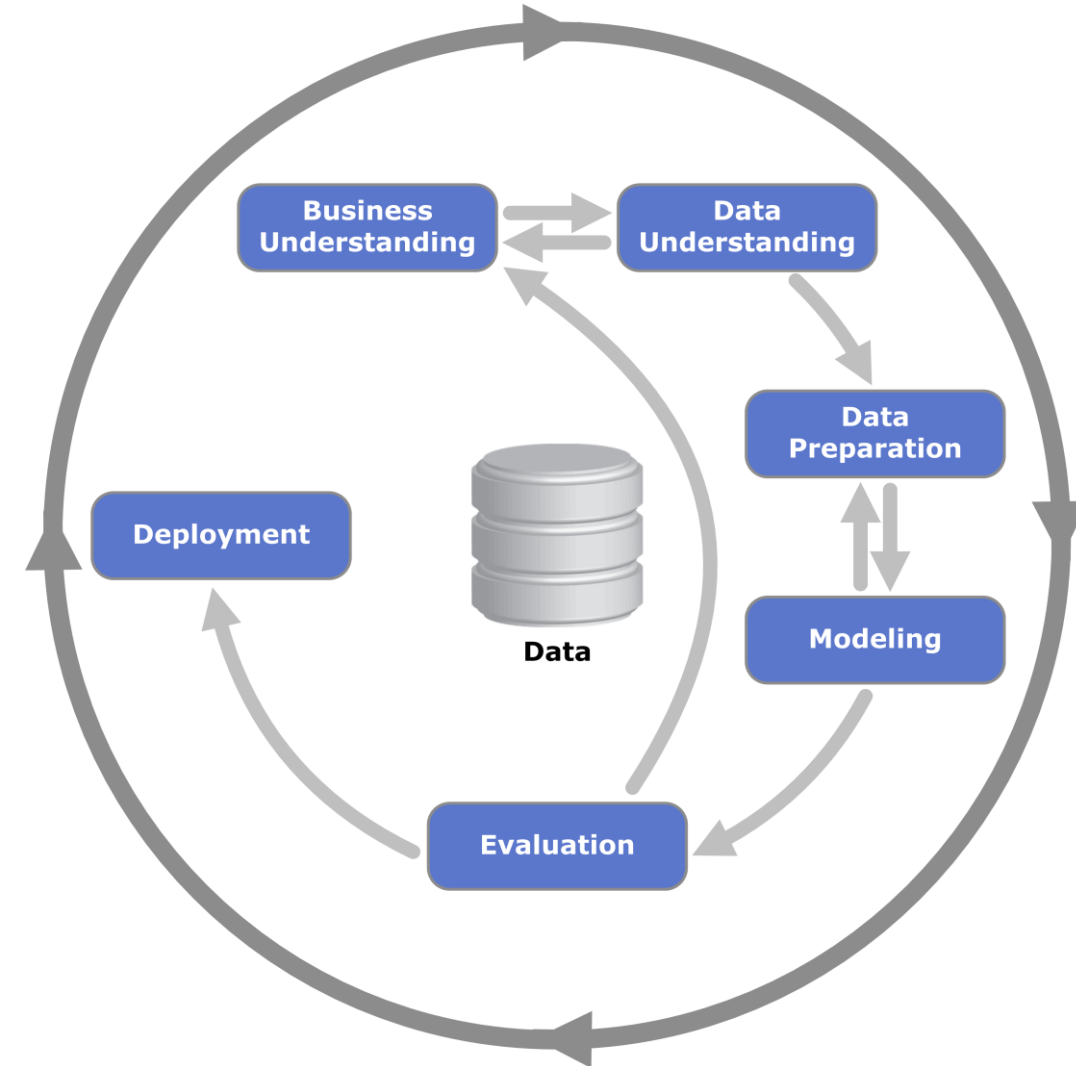



Structured Masters in Chemical Engineering, focus area: Data Analytics

- What do students say?

Content packaged well and presented at a level that enabled students to grasp content... I am still reeling from all the new information and insights.

This was a phenomenal module. Well structured and well prepared for. The tutorials were invaluable!

I have gained a lot of knowledge regarding plantwide dynamics and control. The exposure to the tools and literature will certainly be useful for my growth in this field.

I really enjoyed the block week, not just for the excellent lectures and tutorials, but also for the way in which Prof. Tobi and Prof. Lidia treated us and the effort that was put into the block week. They were friendly, enthusiastic, and extremely knowledgeable... The quizzes were what I would expect from a Master's program - deep and thought-provoking questions, sometimes open-ended (which reflects life), but also respecting our time by not having quizzes that are too long.

Our approach: capacity development

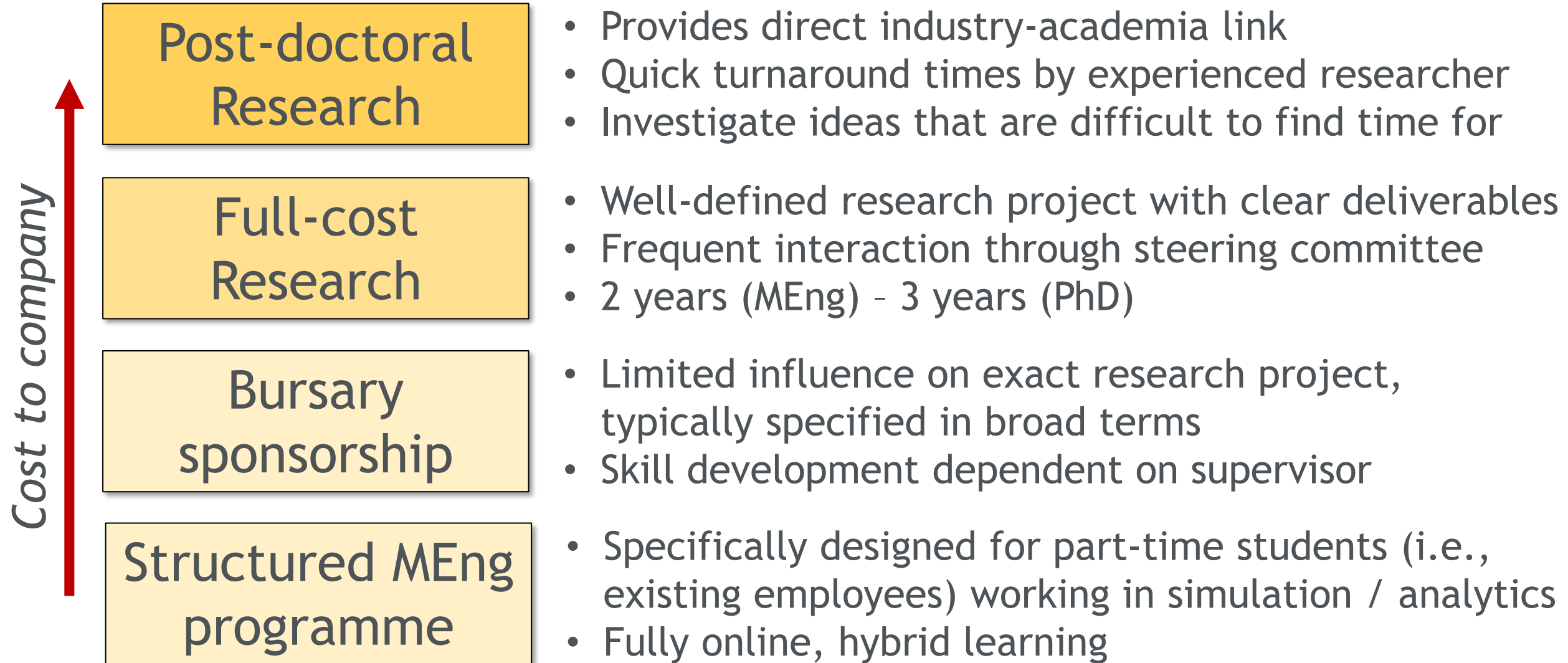

Our approach: capacity development

Cost to company

Post-doctoral
Research

Full-cost
Research

Bursary
sponsorship

Structured MEng
programme

Have
a chat

- Provides direct industry-academia link
- Investigate ideas that are difficult to find time for
- Well-defined research project with clear deliverables
- Frequent interaction through steering committee
- 2 years (MEng) - 3 years (PhD)
- Limited influence on exact research project, typically specified in broad terms
- Skill development dependent on supervisor
- Specifically designed for part-time students (i.e., existing employees) working in simulation / analytics
- Fully online, hybrid learning
- Eager to talk to you about opportunities and challenges related in process modelling
- Build collaboration and community of practice
- tmlouw@sun.ac.za

Thank you
Enkosi
Dankie