

From Models to Systems: Industrialising AI for Real-World Applications



Photo by Stefan Els

- The current challenge
- Our research philosophy
- AI as human-interface
- Three domain examples
 - Predictive maintenance
 - Building management informed data acquisition
 - Manufacturing assembly Virtual commissioning
- Summarize

The core problem

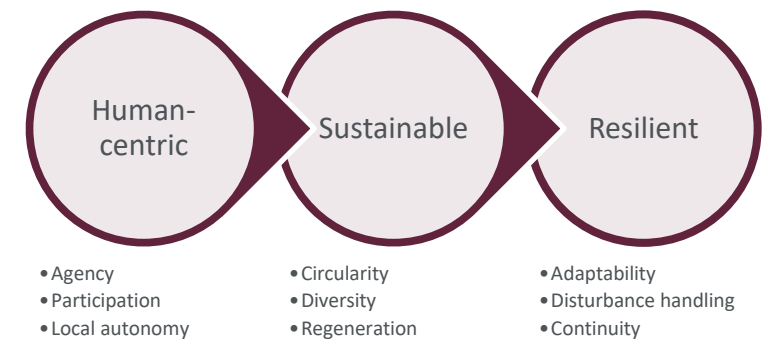
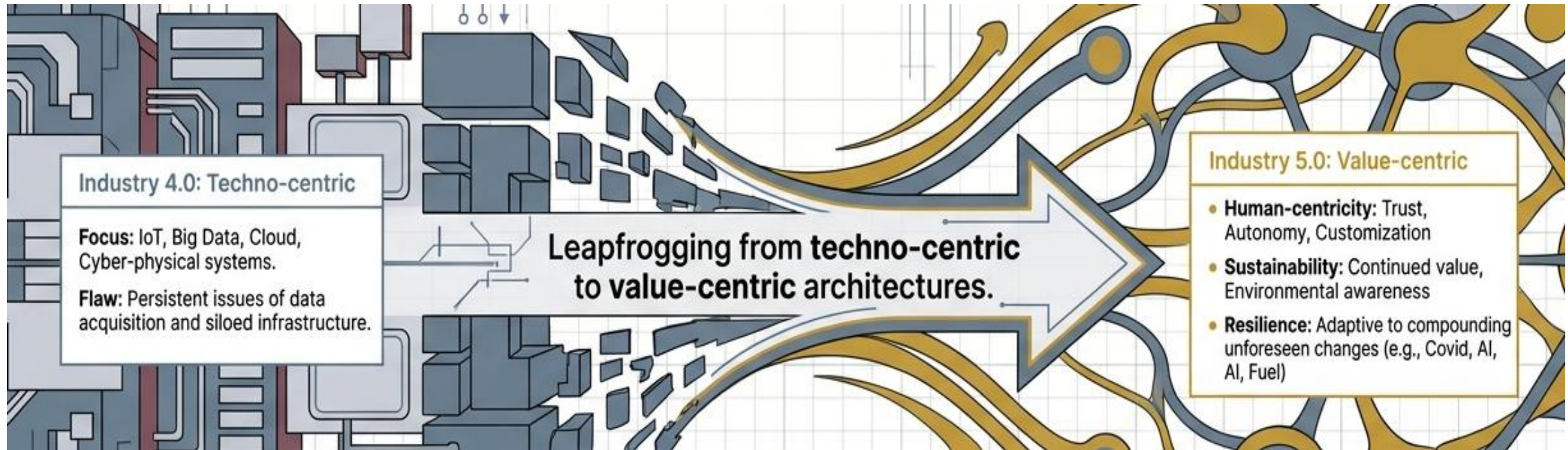

Mechatronic, Automation, and Design Research Group

- Research philosophy
 - Adaptability through complexity
 - Complexity as the interaction between subsystems,
 - Accessibility through human-machine integration



Prof Anton Basson (PrEng)

 Professor Emeritus

 ahb@sun.ac.za



Dr Nicole Taylor

 Lecturer

 nctaylor@sun.ac.za



Dr Clint Steed

 Lecturer

 steed@sun.ac.za

AI as autonomous agents

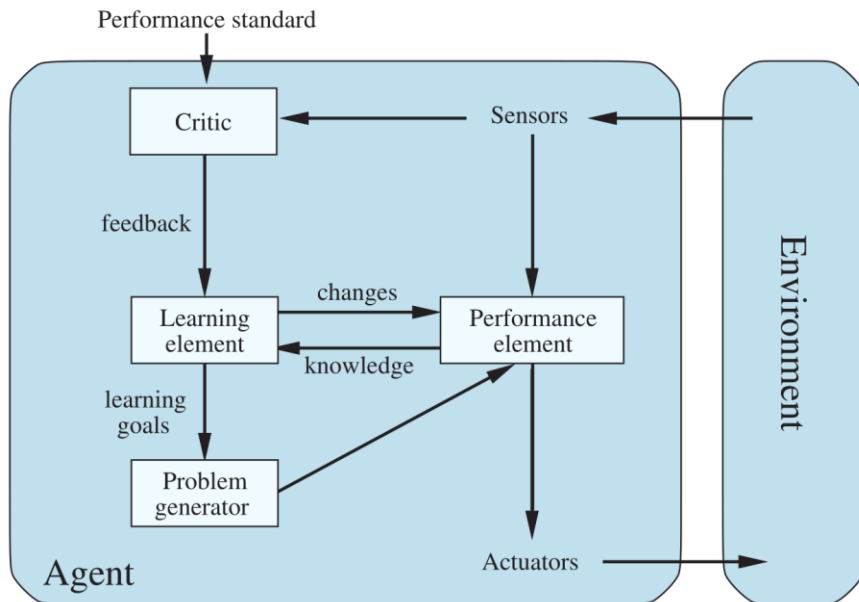

General learning agent. Note: (1) the agent is distinct from its environment, (2) Sensors acquire data, and (3) actuators enable actions.

AI as human-machine intelligence

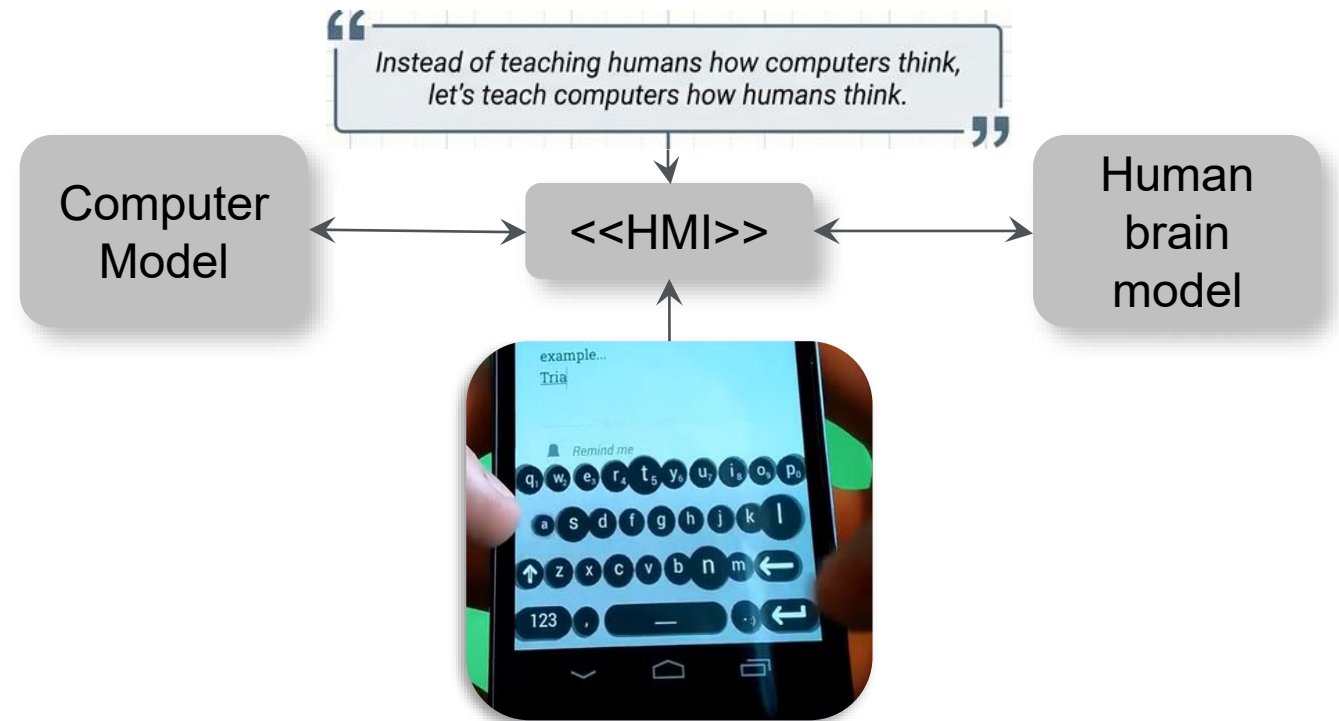

There are two computers/models. The machine and the human brain. We can exploit when these two are similar. A good example is the size of touchscreen key areas are different based on the next letter.

Domain 1: Predictive maintenance in pump houses

Predictive maintenance in pump houses

- Critical water infrastructure
- Human-operator, maintenance, labeling of maintenance outcomes

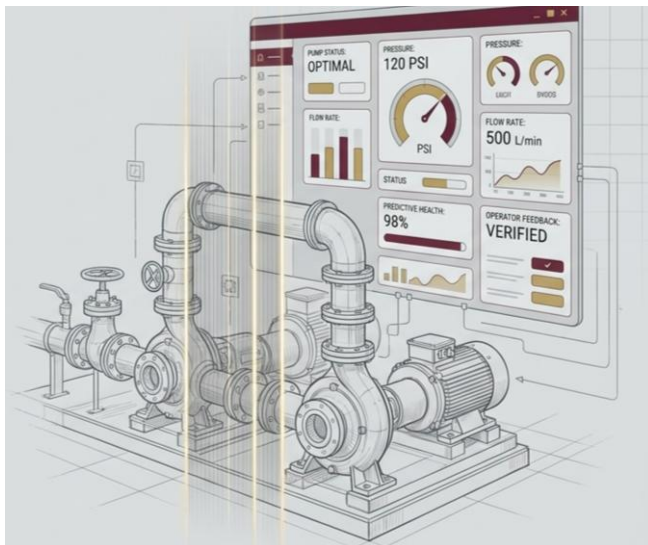

The existing pump SCADA system (left) interacts with Human-MLOps system (right) to predict and label maintenance related faults.

Un-Siloing MLOps: The Human Path in Predictive Maintenance

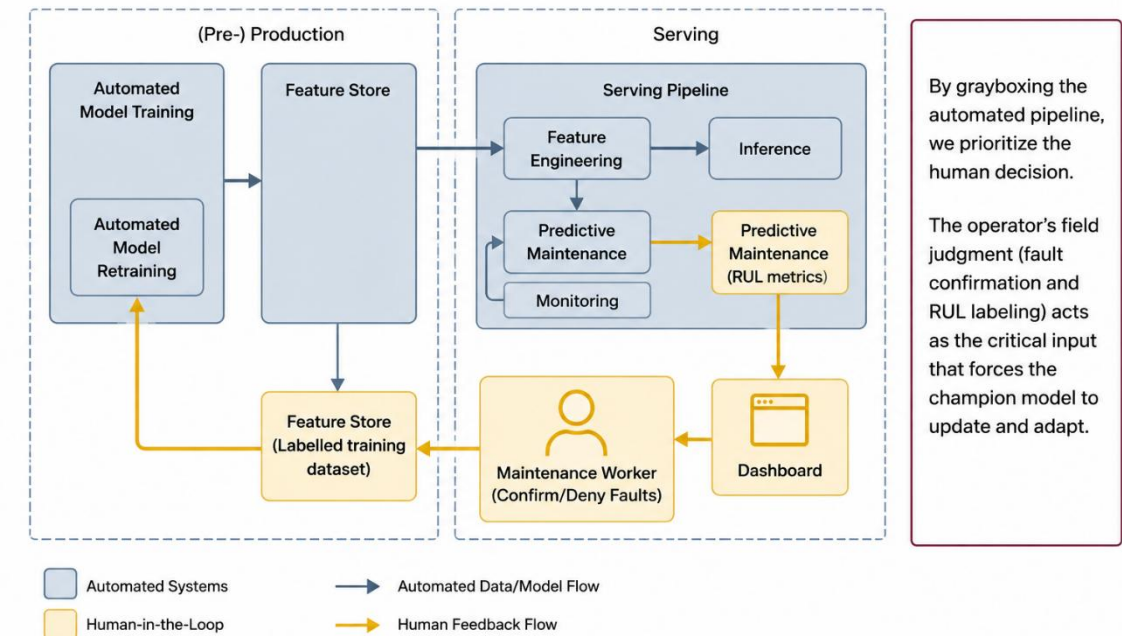

Domain 2: Resource efficiency in (hospital) building

What data would be useful for management decisions?

- Data acquisition needs to be motivated by financial return
- Observability in the face of uncertainty through modeling

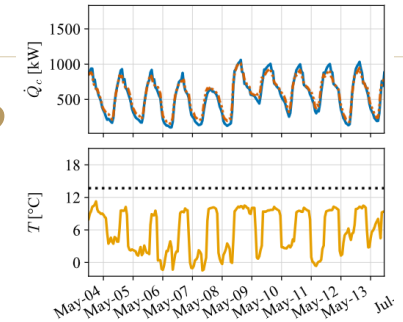

Fit measured data, estimate unmeasured

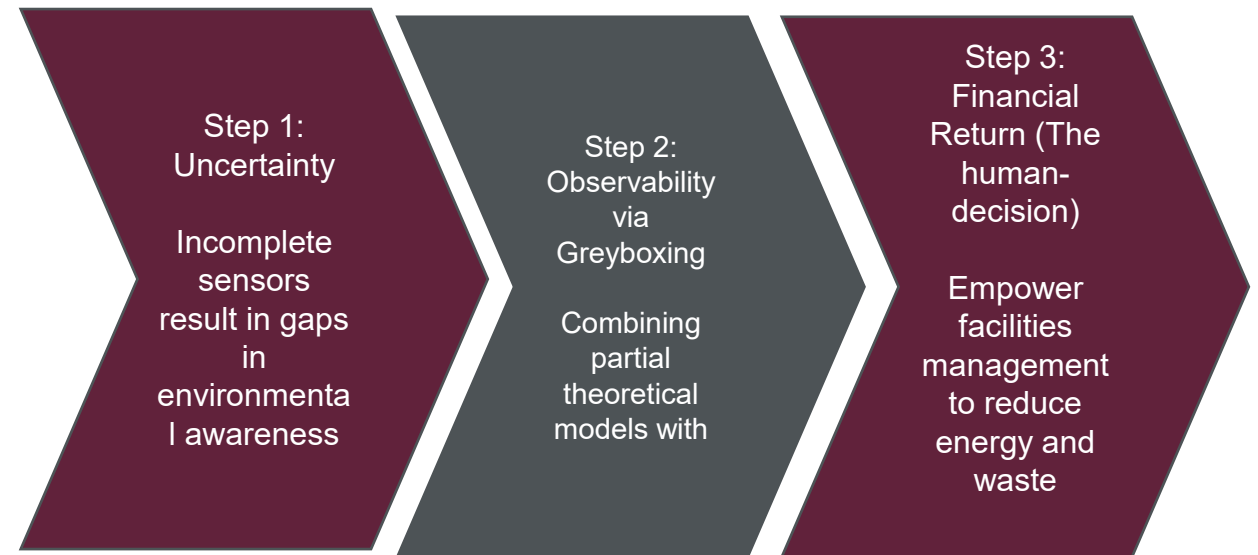
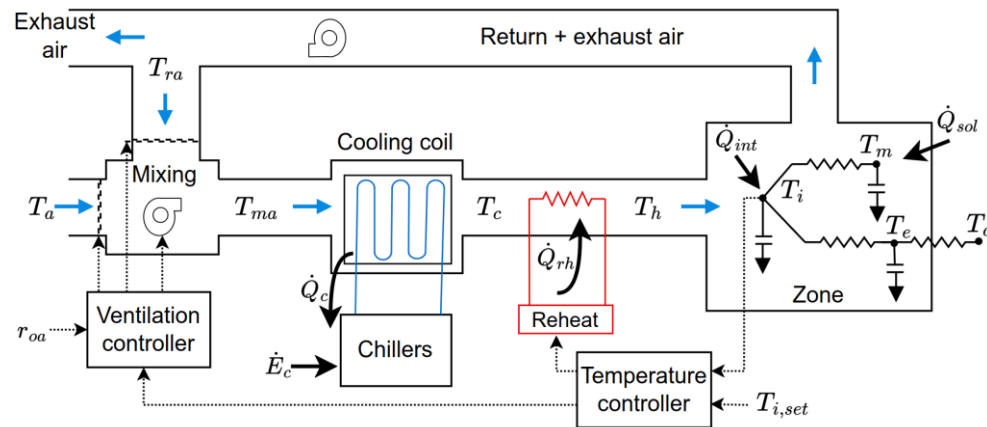

Financial justification of additional data capture

Domain 03: Virtual commissioning via VR HMI for manufacturing assembly

- Virtual Commissioning → Replicating a physical manufacturing environment with a software system. Typically to validate program (PLC, Robot, HMI).
- Key limitations →
 - Discarded after commissioning, Limited reuse
 - Openness (Interoperability vs Vendor lock-in)
 - Human-in-the-loop (Ergonomics, cognitive, operator validated)
- Opportunity of bi-directional improvements
 - Human → VR → Robot: Allow operators to program robots (accessible)
 - Assembly process → VR training → Human performance: Improving manual assembly process (DFA).

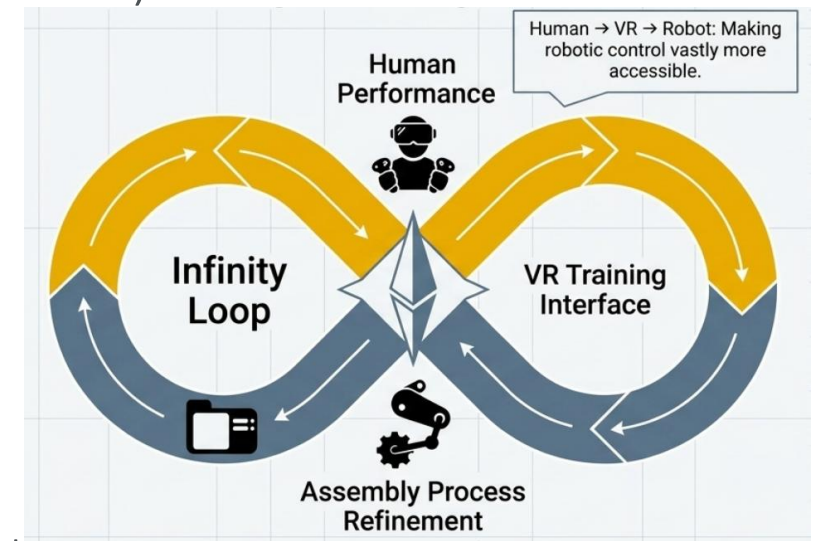

Domain 03: Training operators, developing physical environment, and developing information systems.

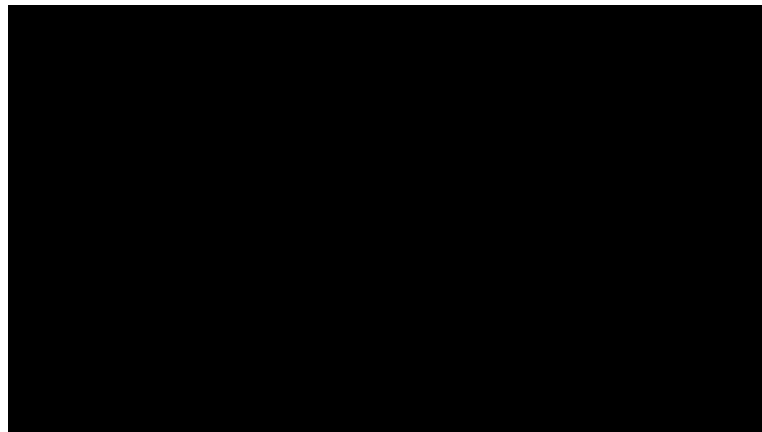
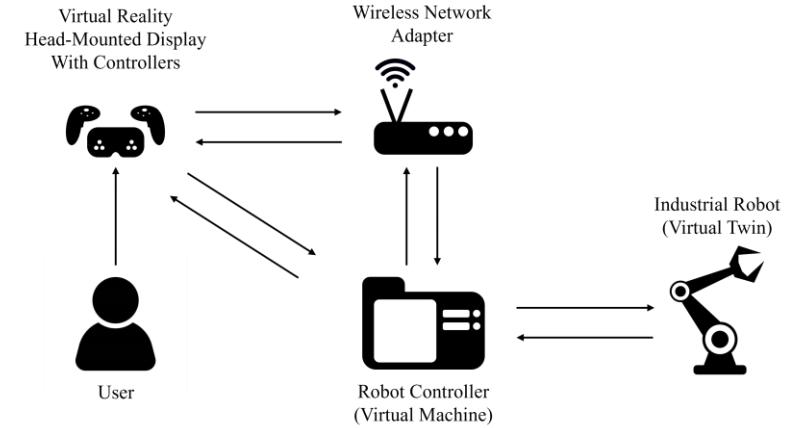
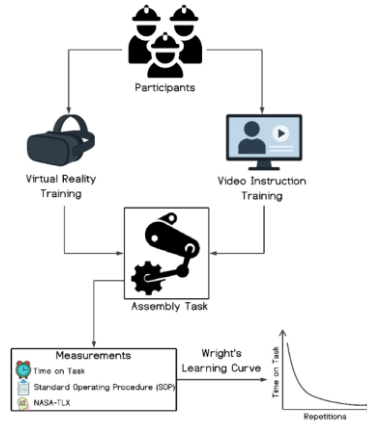

Virtual reality commissioning allows iterative ergonomic design, to increase human operator comfort and performance

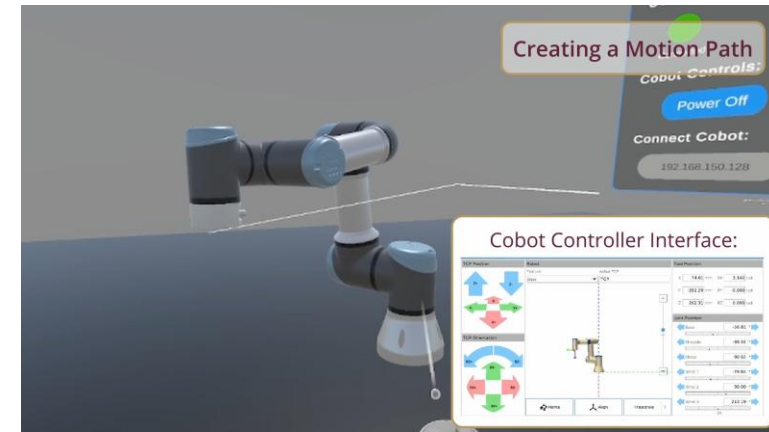

Virtual reality allows an intuitive robot programming, allowing shop floor operators to configure the environment ensuring robot reach.

Pilot Deployments

Deploying predictive maintenance frameworks alongside existing SCADA infrastructure to test Human-in-the-Loop MLOps.

Greybox Modeling

Rapidly mapping uncertain environments (like building energy networks) to identify immediate energy and carbon tax optimizations.

HMI Co-Development

Utilizing VR and advanced simulation to leapfrog vendor lock-in and accelerate workforce training.

What (I think) can you do?

Control your interfaces

Controlling your businesses interfaces allows you to evaluate, compare, and switch tools increasing resilience, while employing relevant tools.

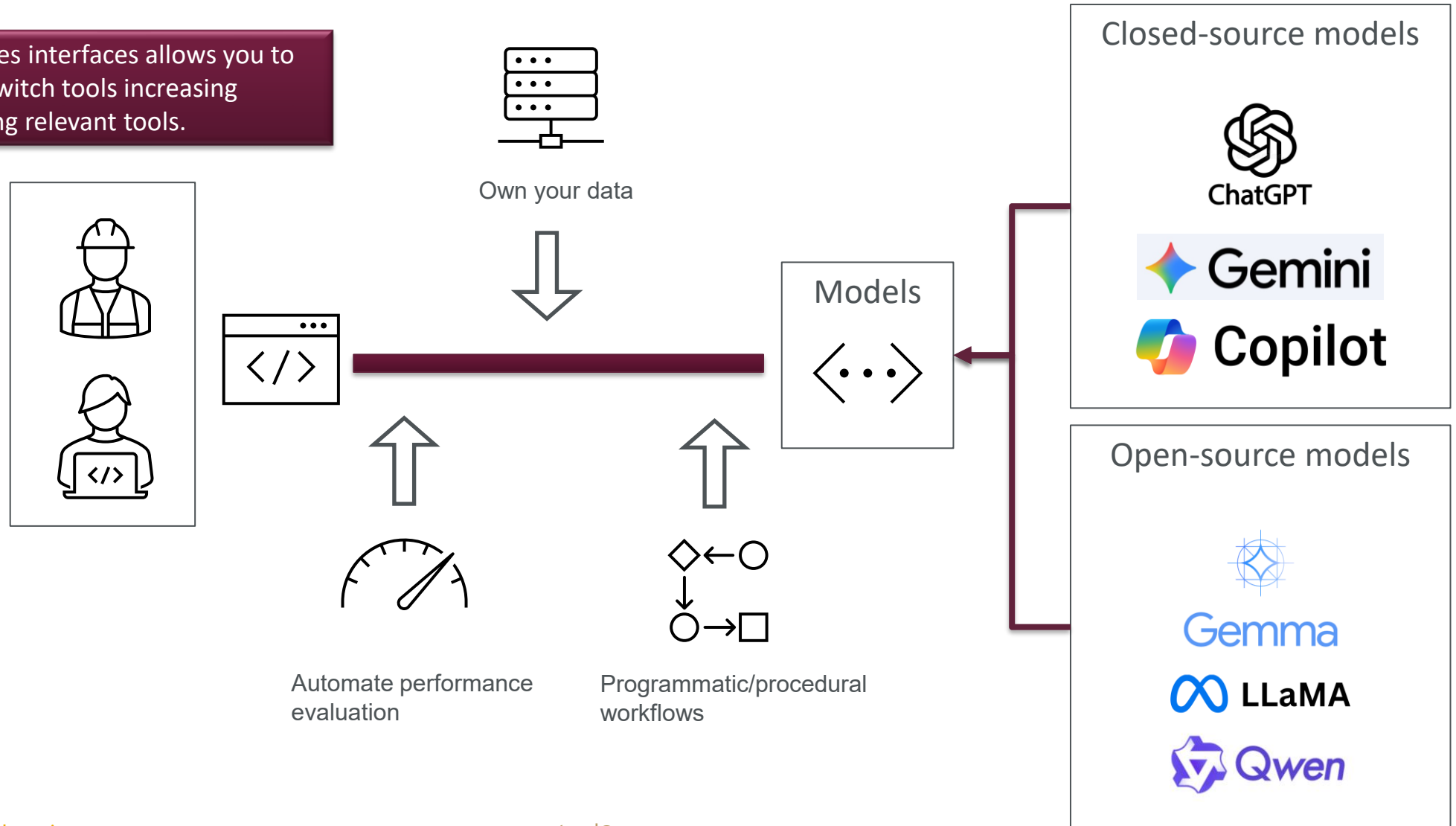

Thank you
Enkosi
Dankie

Contact:

steed@sun.ac.za
nctaylor@sun.ac.za
ahb@sun.ac.za
www.sun.ac.za/mad

Photo by Stefan Els

Three Configurations for Human-AI Collaboration

AI should never oversee humans. It can be governed by humans or work alongside them as equals.

1. Human Governs AI (Human in Charge)

The human sets direction, makes final decisions, and oversees AI systems.

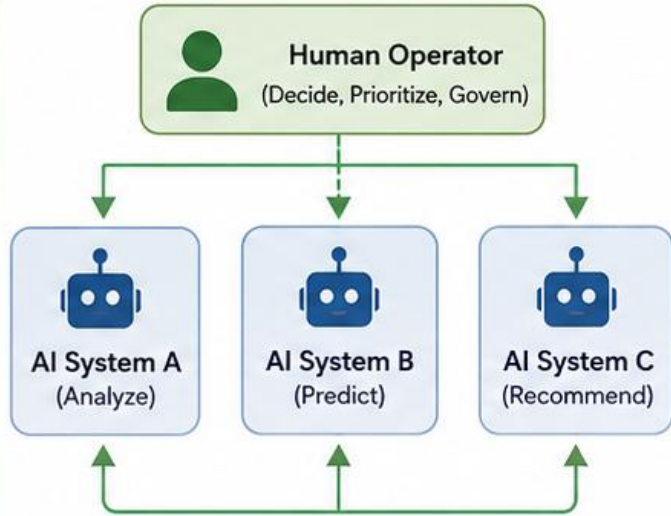

- ✓ Humans set goals, policies, and constraints
- ✓ AI provides insights, predictions, and options
- ✓ Humans make final calls and take responsibility

Principle: Human control and accountability

2. Human-AI as Peers (Co-Creating)

Human and AI collaborate as equals, combining strengths to create better outcomes.

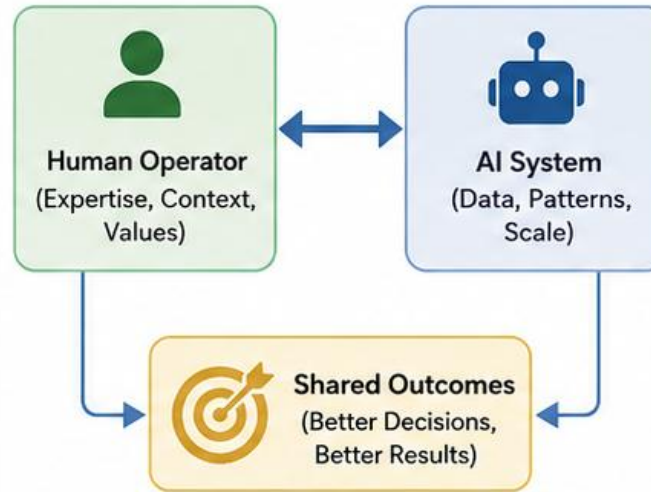

- ✓ Human brings judgment, experience, and ethics
- ✓ AI brings data, speed, and pattern recognition
- ✓ Together they co-create and iterate

Principle: Partnership and mutual respect

3. AI Above Human (Not Acceptable)

AI should never oversee or replace human judgment. This undermines dignity, safety, and accountability.

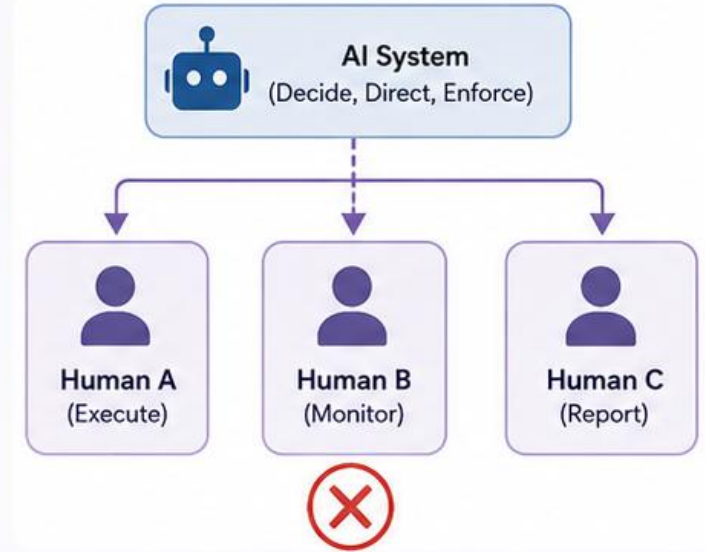

- ✗ AI makes or enforces decisions over humans
- ✗ Humans reduced to mere executors or monitors
- ✗ Risks bias, loss of accountability, and disempowerment

Principle: Not acceptable



Guiding Principle: Technology should empower people, not replace or control them. **Humans first. Always.**