



Stellenbosch
UNIVERSITY
IYUNIVESITHI
UNIVERSITEIT

Print, Place, Reuse: 3D Printed Concrete in Practice



Photo by Stefan Els

3D Concrete Printing



Photo by Travel and Leisure



Photo by Hyperion Robotics



Photo by Parametric Architecture



The Team

Centre for Development of Sustainable Infrastructure



Gideon van
Zijl



Kim Timm



Tata van
Rooyen



Humaira
Fataar



Jacques
Kruger

Unit for Construction Materials



Riaan
Combrinck



Adewumi
Babafemi

Structural Fire Engineering - FireSUN



Richard
Walls



Courtney
Devine



Natalia Florez
Quiroz

The Research

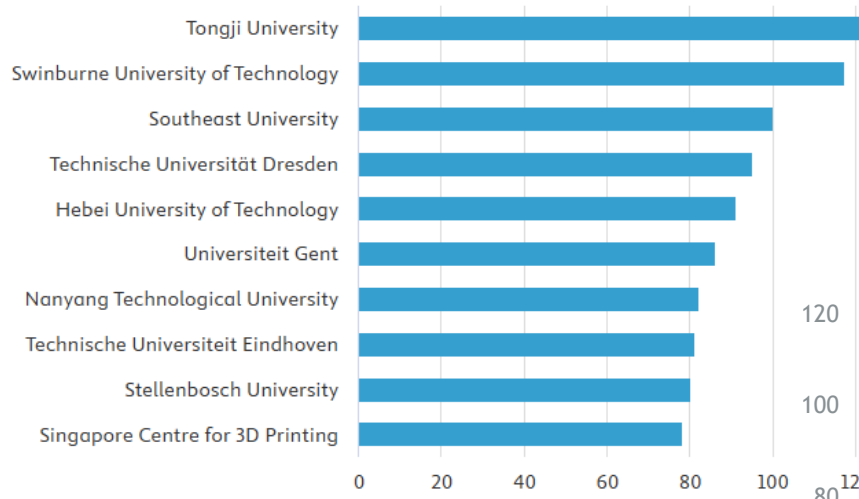

Source Scopus:
3DPC or 3DCP or Digital Fabrication with
Concrete or Additive Construction

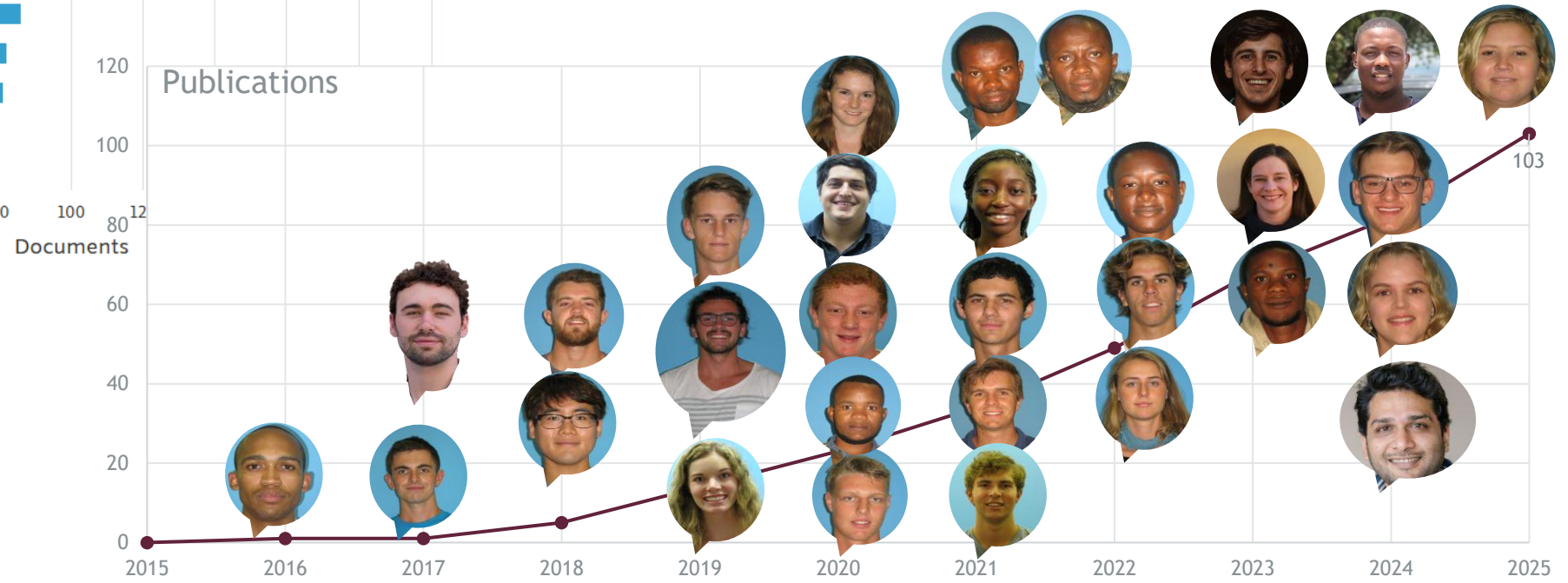

The Research

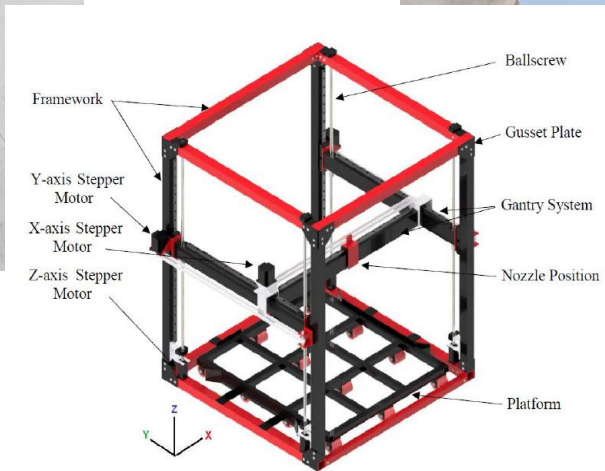
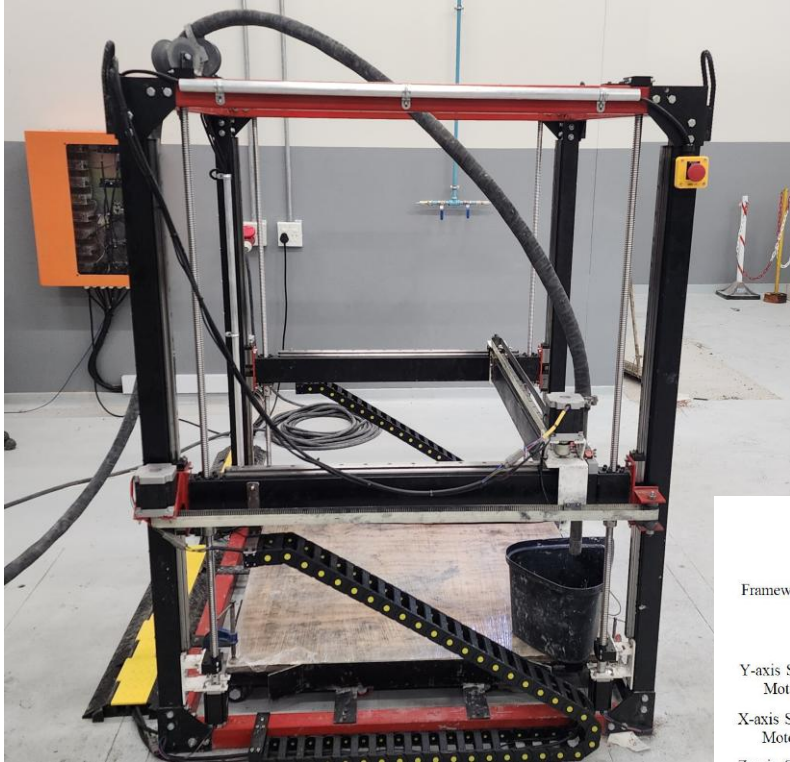

Print, Place, Reuse: 3D Printed Concrete in Practice

The Research

Experimental Cracking Pattern

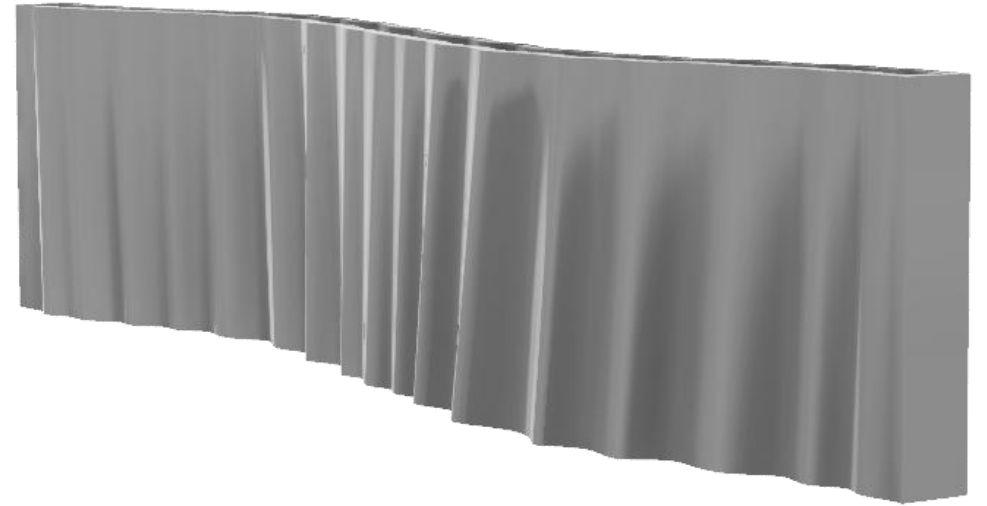
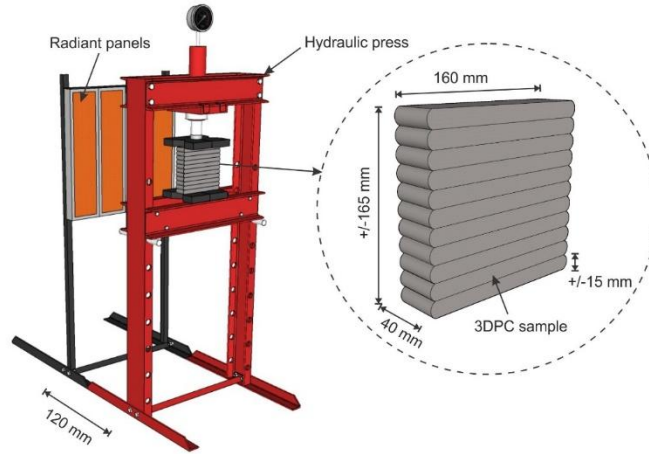

FEM Cracking Pattern

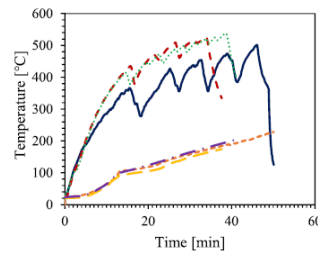
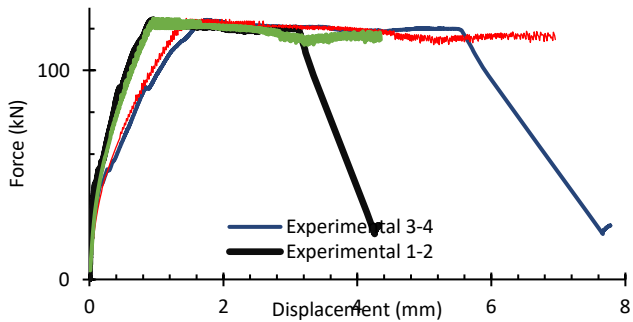
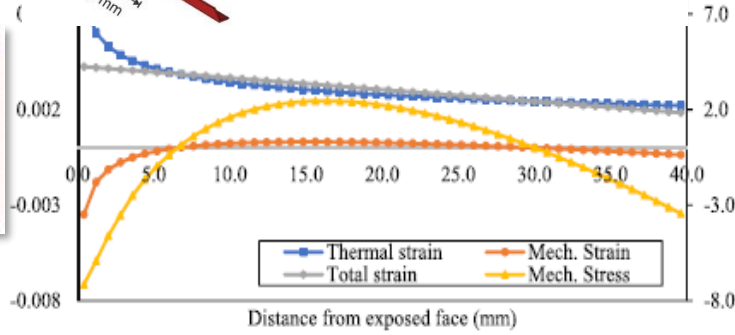
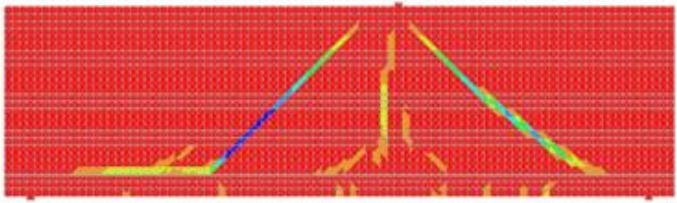

Sustainability

- Local materials
 - Reduced cement & water content
 - Clays (Metakaolin), FA, GGBS
 - Increased aggregate: CDW 25-100%
 - 6.7 mm stone (a/b = 2)

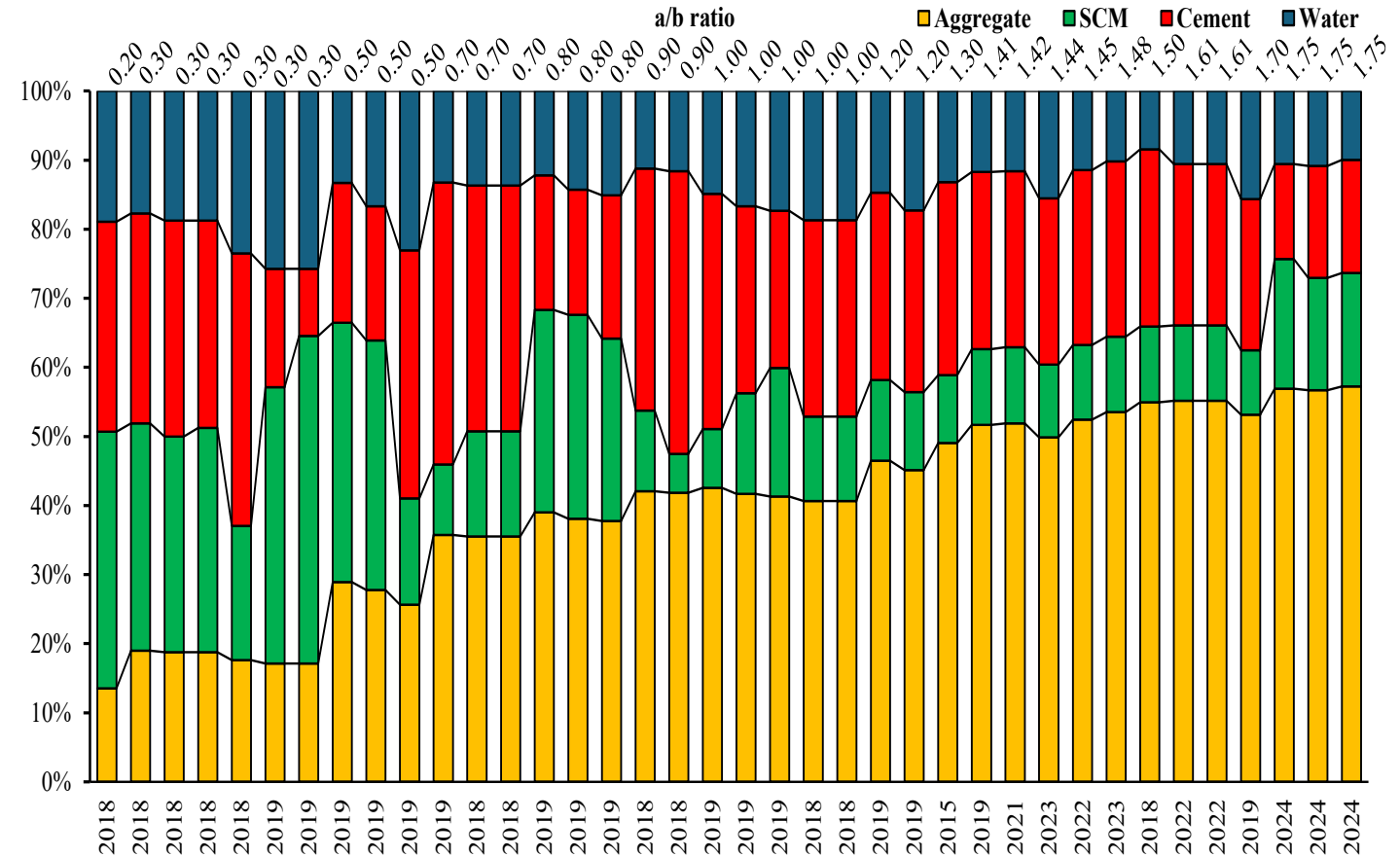

Optimisation and Reuse

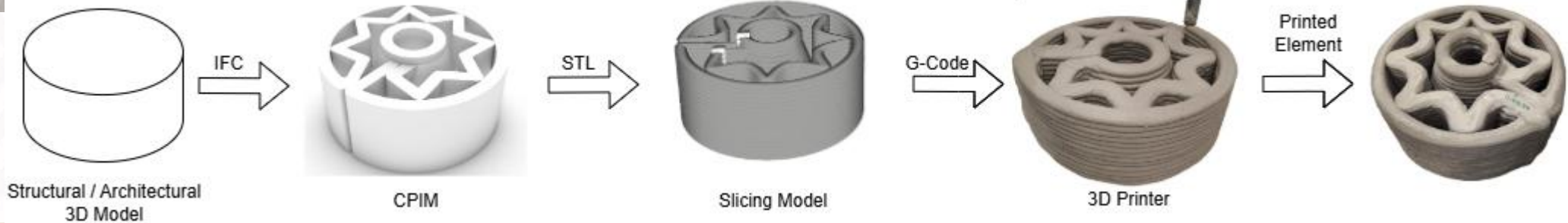
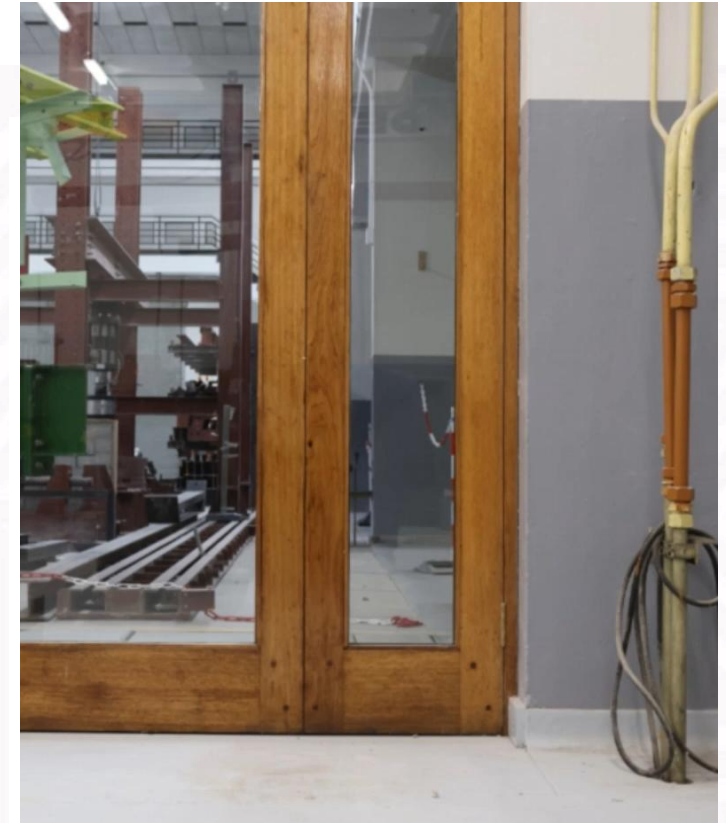
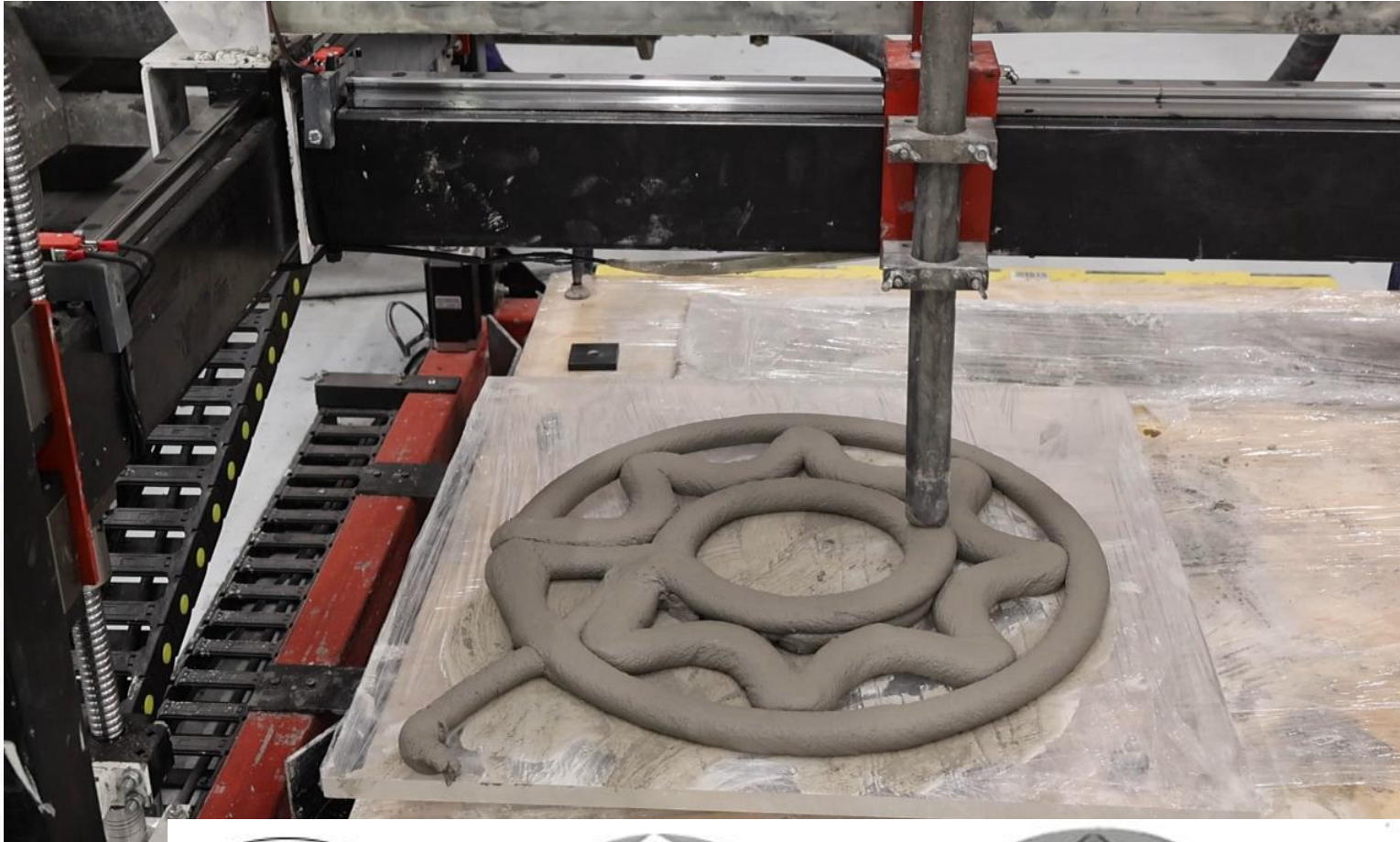

Where to from here?

Photo by Cundall



- Architectural signature structures



Where to from here?

Photo by Cundall

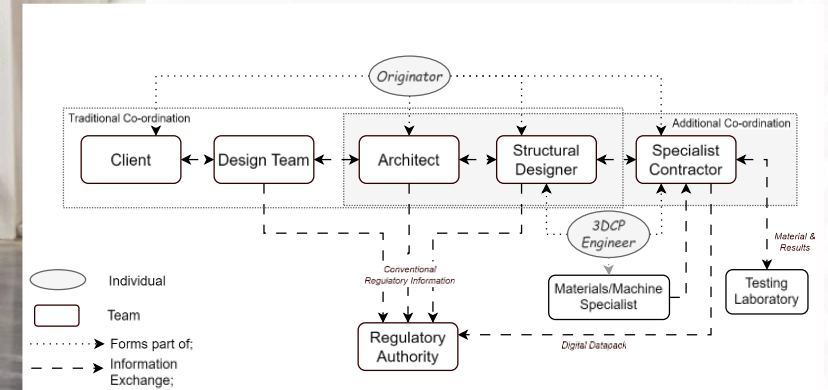
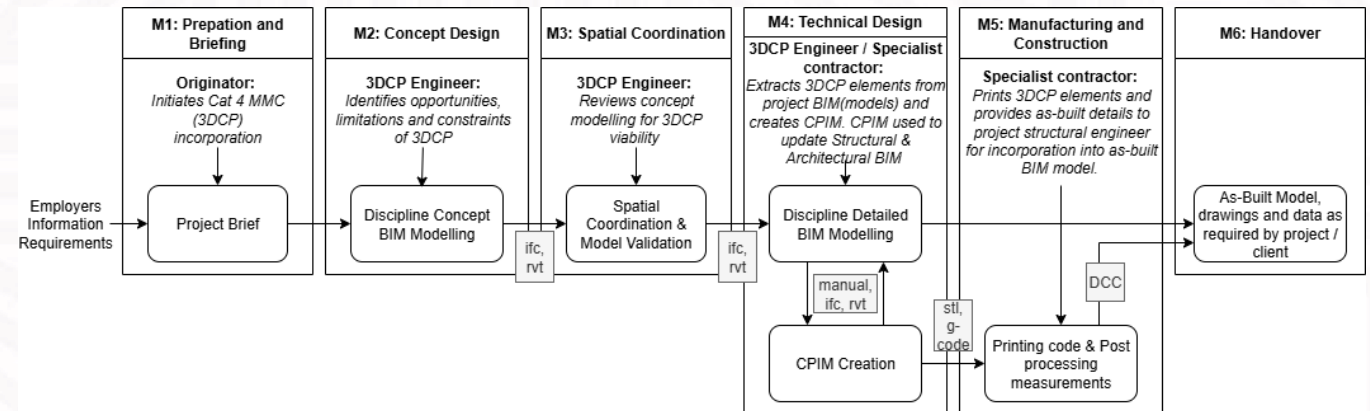

Photo Shutterstock

- Overlap with precast concrete industry



Where to from here?



Photo by Moneyweb

- Practical infrastructure with geometric challenges

Where to from here?



Photos by Kind Designs



- Significant opportunity for environmental initiatives



Photo by Kim Timm

Thank you
Enkosi
Dankie